

Selection diagram

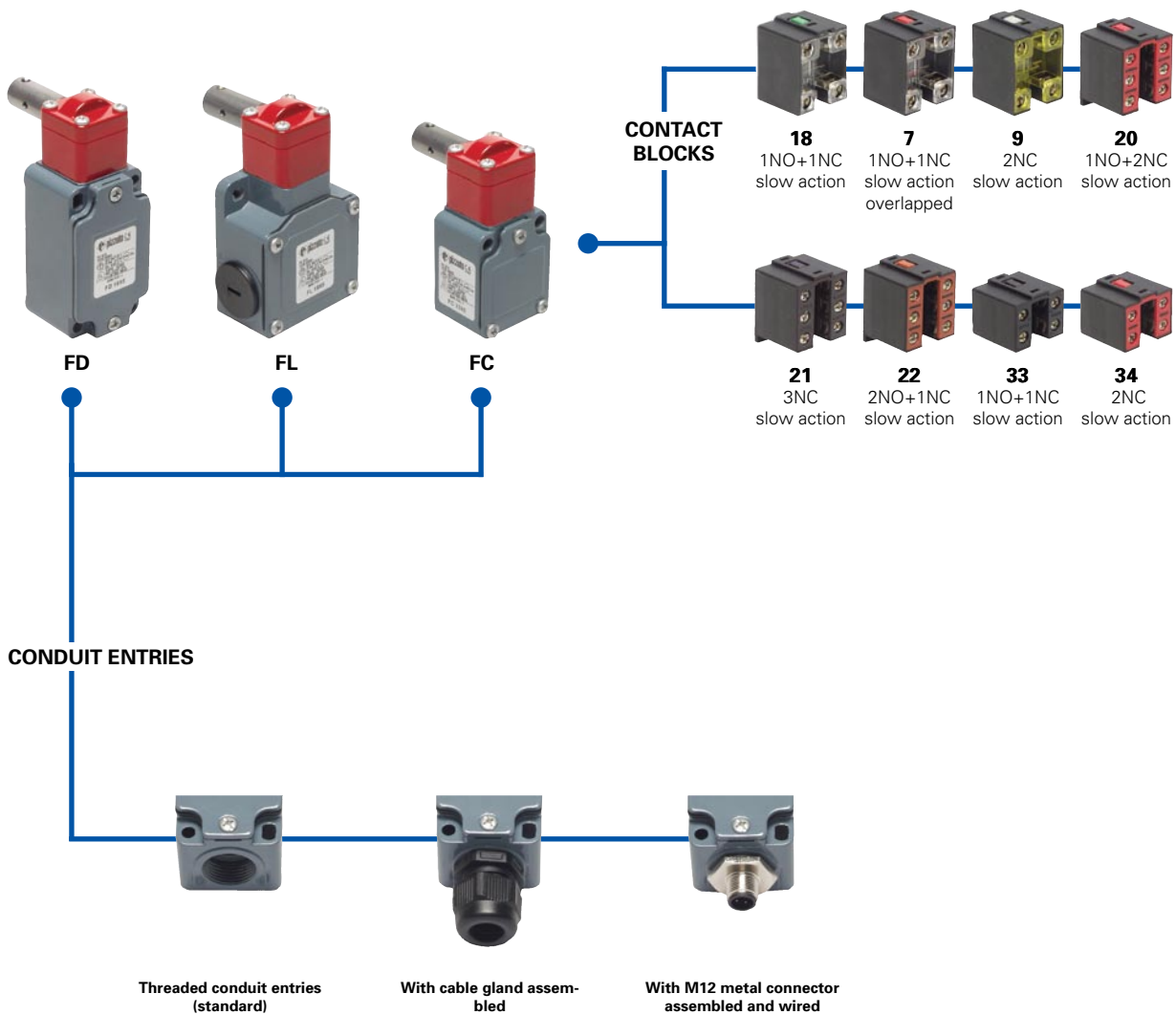

—●— product option  
 —▶— accessory sold separately

**Code structure**

**Attention!** The feasibility of a code number does not mean the effective availability of a product. Please contact our sales office.

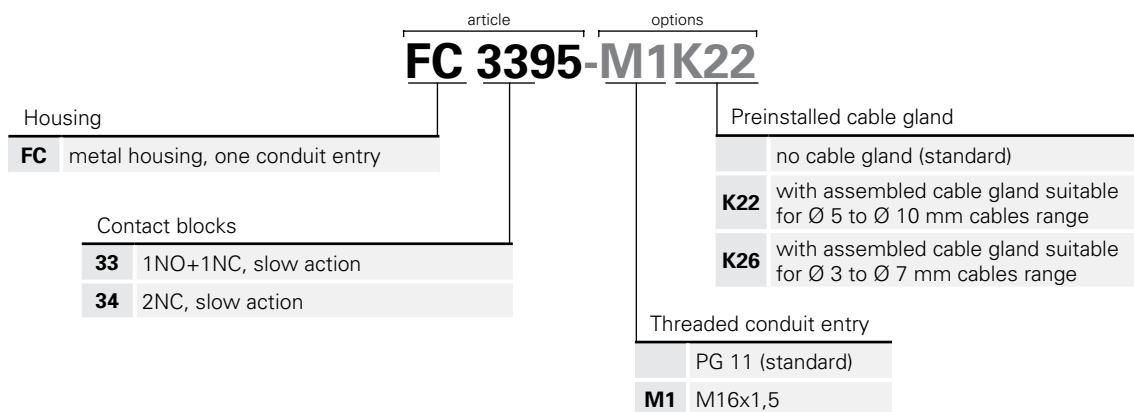
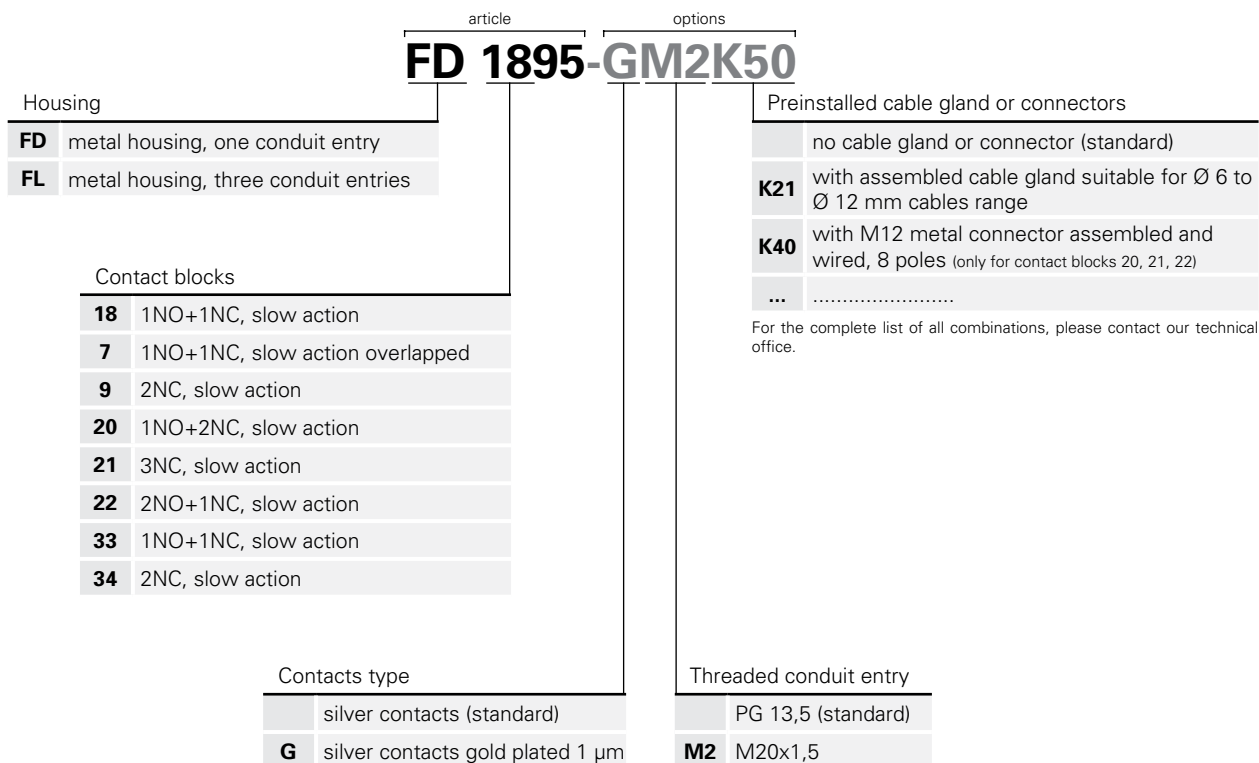



### Main data

- Metal housing, from one to three conduit entries
- Protection degree IP67
- 8 contact blocks available
- Stainless steel actuator
- M12 assembled connector versions
- Silver contacts gold plated versions

### Markings and quality marks:



Approval IMQ: EG605 (FD-FL-FC series)  
 Approval UL: E131787  
 Approval CCC: 2007010305230000  
 (FD-FL-FC series)  
 Approval EZU: 1010151

### Technical data

#### Housing

Housing type FD, FL and FC made of metal, coated with baked epoxy powder. Stainless steel actuator.

FD, FC series one conduit entry

FL series three conduit entries

Protection degree: IP67

#### General data

Ambient temperature: from -25°C to +80°C

Version for operation in ambient temperature from -40°C to +80°C on request

Max operating frequency: 3600 operations cycles<sup>1</sup>/hour

Mechanical endurance: 1 million of operations cycles<sup>1</sup>

Max actuating speed: 180°/s

Min. actuating speed: 2°/s

(1) One operation cycle means two movements, one to close and one to open contacts, as foreseen by IEC 947-5-1 standard.

#### Cross section of the conductors (flexible copper wire)

Contact blocks 20, 21, 22, 33, 34: min. 1 x 0,34 mm<sup>2</sup> (1 x AWG 22)  
 max. 2 x 1,5 mm<sup>2</sup> (2 x AWG 16)

Contact blocks 7, 9, 18: min. 1 x 0,5 mm<sup>2</sup> (1 x AWG 20)  
 max. 2 x 2,5 mm<sup>2</sup> (2 x AWG 14)

#### In conformity with standards:

IEC 60947-5-1, EN 60947-5-1, IEC 60204-1, EN 60204-1, EN 1088, EN ISO 12100-1, EN ISO 12100-2, IEC 529, EN 60529, NFC 63-140, VDE 0660-200, VDE 0113, CENELEC EN 50013.

#### Approvals:

IEC 60947-5-1, UL 508, GB14048.5-2001

#### In conformity with requirements requested by:

Low Voltage Directive 2006/95/EC, Machinery Directive 2006/42/EC and Electromagnetic Compatibility 2004/108/EC.

#### Positive contact opening in conformity with standards:

IEC 60947-5-1, EN 60947-5-1, VDE 0660-206.

**⚠ If not expressly indicated in this chapter, for the right installation and the correct utilization of all articles see requirements indicated from page 6/1 to page 6/8.**

#### Electrical data

#### Utilization categories

without connector	Thermal current (I <sub>th</sub> ):	10 A	Alternate current: AC15 (50...60 Hz)			
	Rated insulation voltage (U <sub>i</sub> ):	500 VAC 600 VDC	U <sub>e</sub> (V)	250	400	500
Protection against short circuits:	Pollution degree:	400 VAC for contact blocks 20, 21, 22, 33, 34	I <sub>e</sub> (A)	6	4	1
		fuse 10 A 500 V type aM	Direct current: DC13			
		3	U <sub>e</sub> (V)	24	125	250
			I <sub>e</sub> (A)	6	1,1	0,4

with 5 poles M12 connector	Thermal current (I <sub>th</sub> ):	4 A	Alternate current: AC15 (50...60 Hz)			
	Rated insulation voltage (U <sub>i</sub> ):	250 VAC 300 VDC	U <sub>e</sub> (V)	24	120	250
Protection against short circuits:	Pollution degree:	fuse 4 A 500 V type gG	I <sub>e</sub> (A)	4	4	4
		3	Direct current: DC13			
			U <sub>e</sub> (V)	24	125	250
			I <sub>e</sub> (A)	4	1,1	0,4

with 8 poles M12 connector	Thermal current (I <sub>th</sub> ):	2 A	Alternate current: AC15 (50...60 Hz)			
	Rated insulation voltage (U <sub>i</sub> ):	30 VAC 36 VDC	U <sub>e</sub> (V)	24		
Protection against short circuits:	Pollution degree:	fuse 2 A 500 V type gG	I <sub>e</sub> (A)	2		
		3	Direct current: DC13			
			U <sub>e</sub> (V)	24		
			I <sub>e</sub> (A)	2		

## Description

These safety switches have been designed to control gates or guards which protect against hazardous parts of the machines. They are very sensitive and positively open the contacts after few degrees of rotation, sending an immediate stop signal. The head may rotate in 90° steps, allowing its installation in a great variety of positions.

The metal housing and the stainless steel actuator allow this switch to be used even in hard environments where sedimented powder or dirty could block working of safety switches with separated actuator.

## Rotating heads

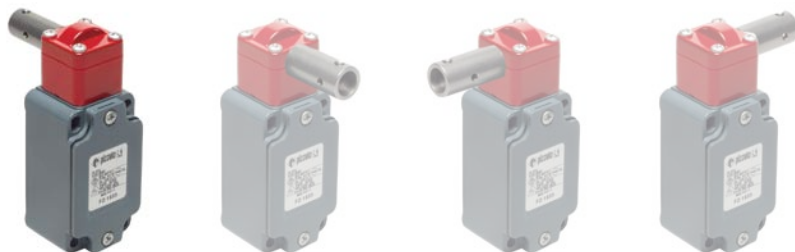

Removing the four fastening screws, in all switches, it is possible to rotate the head in 90° steps.

## Installation examples

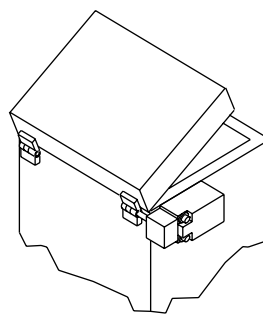
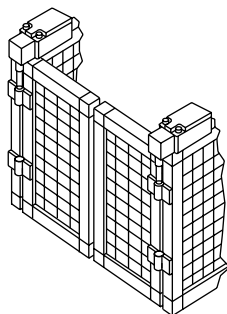

## Data type approved by IMQ, CCC and EZU

Rated insulation voltage (Ui): 500 VAC  
400 VAC for contact blocks 20, 21, 22, 33, 34

Thermal current (Ith): 10 A

Protection against short circuits: fuse 10 A 500 V type aM

Protection degree: IP67

MV terminals (screw clamps)

Pollution degree 3

Utilization category: AC15

Operation voltage (Ue): 400 VAC (50 Hz)

Operation current (Ie): 3 A

Forms of the contact element: Zb, Y+Y, Y+Y+X, Y+Y+Y, Y+X+X

Positive opening of contacts on contact block 7, 9, 18, 20, 21, 22, 33, 34

In conformity with standards: EN60947-1, EN 60947-5-1 and subsequent modifications and completions, fundamental requirements of the Low Voltage Directive 73/23 EEC and subsequent modifications and completions.

Please contact our technical service for the list of type approved products.

## Data type approved by UL

Utilization categories Q300 (69 VA, 125-250 VDC)  
A600 (720 VA, 120-600 VAC)

Data of the housing type 1, 4X (indoor use only), 12, 13

In conformity with standard: UL 508

For all contact blocks use 60 or 75 °C copper (Cu) conductor and wire size No. 12-14 AWG. Terminal tightening torque of 7,1 Lb-In.

Please contact our technical service for the list of type approved products.

Dimensional drawings

Contacts type:  
**L** = slow action  
**LO** = slow action overlapped

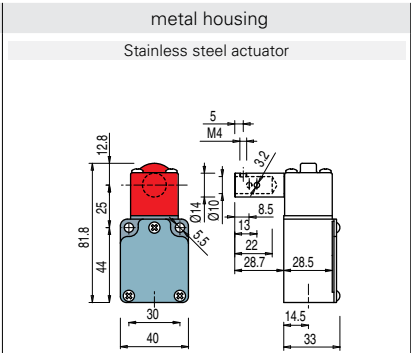
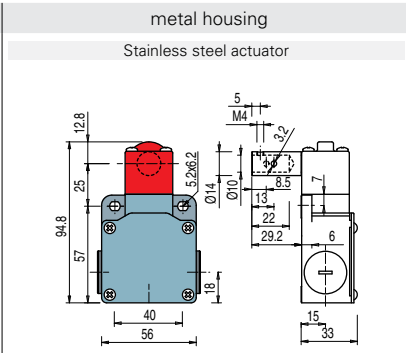
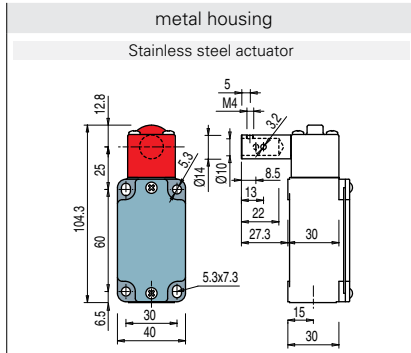

Contact blocks

18	<b>L</b>	<b>FD 1895</b> 1NO+1NC 	<b>FL 1895</b> 1NO+1NC 	
7	<b>LO</b>	<b>FD 795</b> 1NO+1NC 	<b>FL 795</b> 1NO+1NC 	
9	<b>L</b>	<b>FD 995</b> 2NC 	<b>FL 995</b> 2NC 	
20	<b>L</b>	<b>FD 2095</b> 1NO+2NC 	<b>FL 2095</b> 1NO+2NC 	
21	<b>L</b>	<b>FD 2195</b> 3NC 	<b>FL 2195</b> 3NC 	
22	<b>L</b>	<b>FD 2295</b> 2NO+1NC 	<b>FL 2295</b> 2NO+1NC 	
33	<b>L</b>	<b>FD 3395</b> 1NO+1NC 	<b>FL 3395</b> 1NO+1NC 	<b>FC 3395</b> 1NO+1NC 
34	<b>L</b>	<b>FD 3495</b> 2NC 	<b>FL 3495</b> 2NC 	<b>FC 3495</b> 2NC 
Min. force		0,15 Nm (0,4 Nm )	0,15 Nm (0,4 Nm )	0,15 Nm (0,4 Nm )

How to read travel diagrams

All measures in the diagrams are in degrees

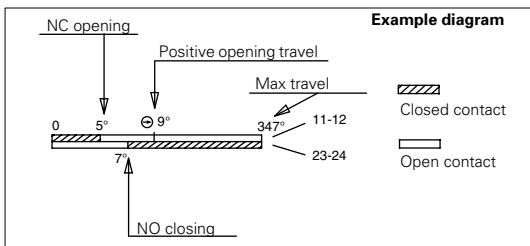

IMPORTANT:

In safety applications it is necessary to activate the switch **at least up to the positive opening point** indicated in the diagrams with the symbol ⊕. Operate the switch **at least with the positive opening force**, indicated between brackets, below each article, next the value of minimum force.

