

Selection diagram

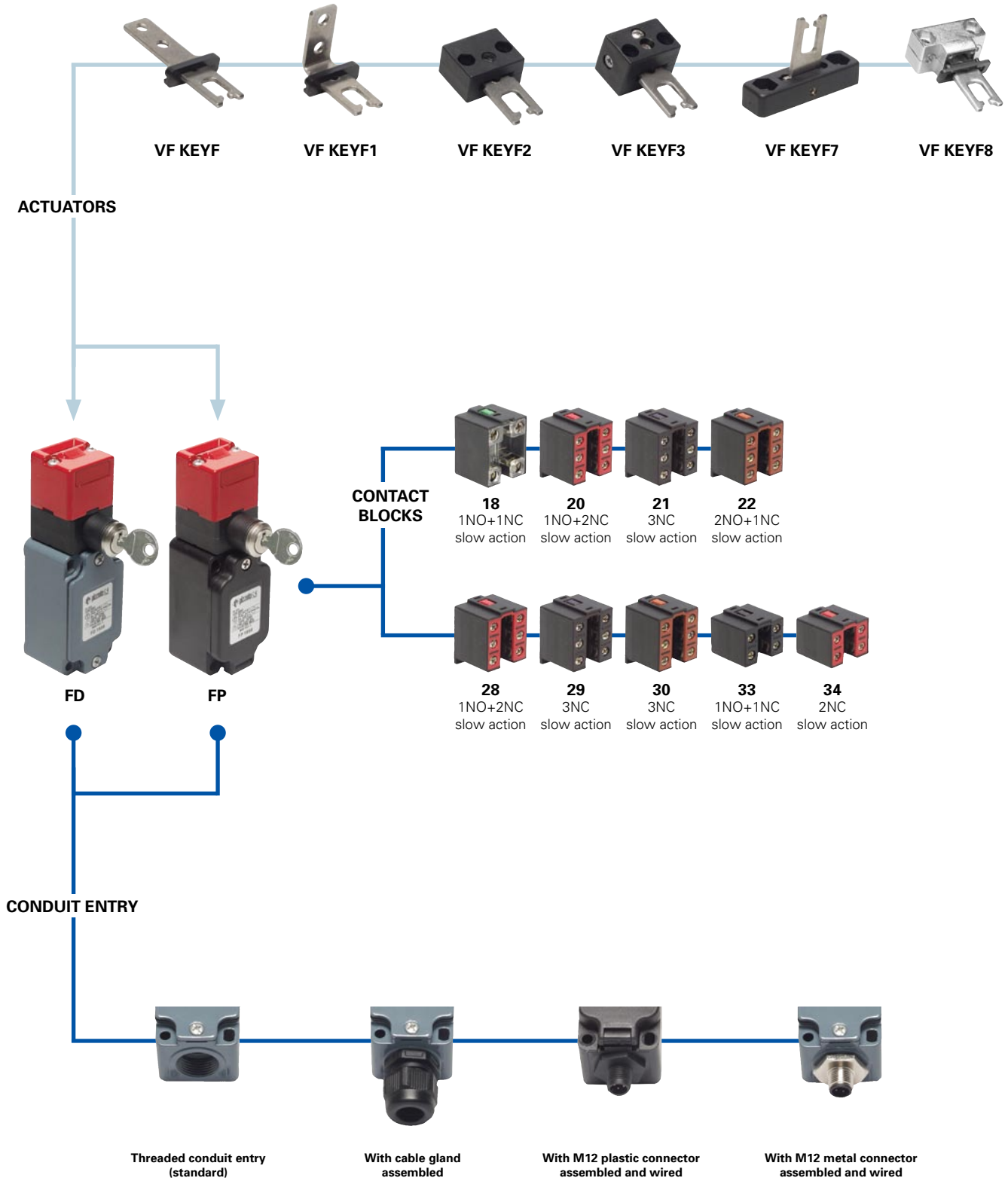

● product option  
 → accessory sold separately

## Working cycle (FP 2899-F1 )

The switch is fixed to the machine body (A), while the stainless steel actuator is fastened to the guard (B). Once installed, the switch will firmly lock the actuator. To remove the actuator, it is necessary to unlock the key locking device rotating the key (C). When the actuator is removed, the key cannot be put in the starting position anymore.

In the example is pointed out how it is possible to have contacts moved by the key lock or by the actuator and how it is possible to install the switch inside the machine, keeping externally visible only the release device.

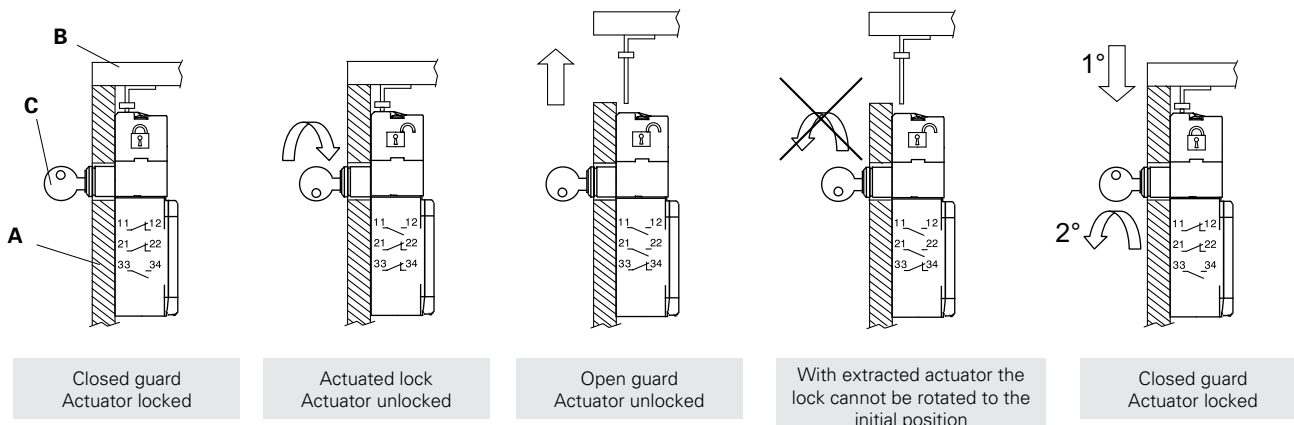

## Code structure

**Attention!** The feasibility of a code number does not mean the effective availability of a product. Please contact our sales office.

article options

# FD 1899-F1GM2K50

<p><b>Housing</b></p> <table border="1" style="width: 100%; border-collapse: collapse;"> <tr> <td style="width: 5%;"><b>FD</b></td> <td>metal housing, one conduit entry</td> </tr> <tr> <td><b>FP</b></td> <td>polymer housing, one conduit entry</td> </tr> </table> <p><b>Contact blocks</b></p> <table border="1" style="width: 100%; border-collapse: collapse;"> <thead> <tr> <th></th> <th>Contact activated by the lock</th> <th>Contact activated by the actuator</th> </tr> </thead> <tbody> <tr> <td><b>18</b></td> <td>1NO+1NC</td> <td></td> </tr> <tr> <td><b>20</b></td> <td>1NO+2NC</td> <td></td> </tr> <tr> <td><b>21</b></td> <td>3NC</td> <td></td> </tr> <tr> <td><b>22</b></td> <td>2NC+1NO</td> <td></td> </tr> <tr> <td><b>28</b></td> <td>1NO+1NC</td> <td>1NC</td> </tr> <tr> <td><b>29</b></td> <td>2NC</td> <td>1NC</td> </tr> <tr> <td><b>30</b></td> <td>1NC</td> <td>2NC</td> </tr> <tr> <td><b>33</b></td> <td>1NO+1NC</td> <td></td> </tr> <tr> <td><b>34</b></td> <td>2NC</td> <td></td> </tr> </tbody> </table> <p><b>Actuators</b></p> <table border="1" style="width: 100%; border-collapse: collapse;"> <tr> <td></td> <td>without actuator (standard)</td> </tr> <tr> <td><b>F</b></td> <td>with straight actuator</td> </tr> <tr> <td><b>F1</b></td> <td>with right-angled actuator</td> </tr> <tr> <td><b>F2</b></td> <td>with jointed actuator</td> </tr> <tr> <td><b>F3</b></td> <td>with jointed actuator adjustable in two directions</td> </tr> <tr> <td><b>F7</b></td> <td>with jointed actuator adjustable in one direction</td> </tr> <tr> <td><b>F8</b></td> <td>with universal actuator</td> </tr> </table>	<b>FD</b>	metal housing, one conduit entry	<b>FP</b>	polymer housing, one conduit entry		Contact activated by the lock	Contact activated by the actuator	<b>18</b>	1NO+1NC		<b>20</b>	1NO+2NC		<b>21</b>	3NC		<b>22</b>	2NC+1NO		<b>28</b>	1NO+1NC	1NC	<b>29</b>	2NC	1NC	<b>30</b>	1NC	2NC	<b>33</b>	1NO+1NC		<b>34</b>	2NC			without actuator (standard)	<b>F</b>	with straight actuator	<b>F1</b>	with right-angled actuator	<b>F2</b>	with jointed actuator	<b>F3</b>	with jointed actuator adjustable in two directions	<b>F7</b>	with jointed actuator adjustable in one direction	<b>F8</b>	with universal actuator	<p><b>Preinstalled cable gland or connectors</b></p> <table border="1" style="width: 100%; border-collapse: collapse;"> <tr> <td></td> <td>no cable gland or connector (standard)</td> </tr> <tr> <td><b>K21</b></td> <td>with assembled cable gland suitable for Ø 6 to Ø 12 mm cables range</td> </tr> <tr> <td><b>K40</b></td> <td>with M12 metal connector assembled and wired, 8 poles (only for contact blocks 20, 21, 22, 28, 29, 30)</td> </tr> <tr> <td>...</td> <td>.....</td> </tr> </table> <p>For the complete list of all combinations, please contact our technical office.</p> <p><b>Threaded conduit entry</b></p> <table border="1" style="width: 100%; border-collapse: collapse;"> <tr> <td></td> <td>PG 13,5 (standard)</td> </tr> <tr> <td><b>M2</b></td> <td>M20x1,5</td> </tr> </table> <p><b>Contacts type</b></p> <table border="1" style="width: 100%; border-collapse: collapse;"> <tr> <td></td> <td>silver contacts (standard)</td> </tr> <tr> <td><b>G</b></td> <td>silver contacts gold plated 1 µm</td> </tr> </table>		no cable gland or connector (standard)	<b>K21</b>	with assembled cable gland suitable for Ø 6 to Ø 12 mm cables range	<b>K40</b>	with M12 metal connector assembled and wired, 8 poles (only for contact blocks 20, 21, 22, 28, 29, 30)	...	.....		PG 13,5 (standard)	<b>M2</b>	M20x1,5		silver contacts (standard)	<b>G</b>	silver contacts gold plated 1 µm
<b>FD</b>	metal housing, one conduit entry																																																																
<b>FP</b>	polymer housing, one conduit entry																																																																
	Contact activated by the lock	Contact activated by the actuator																																																															
<b>18</b>	1NO+1NC																																																																
<b>20</b>	1NO+2NC																																																																
<b>21</b>	3NC																																																																
<b>22</b>	2NC+1NO																																																																
<b>28</b>	1NO+1NC	1NC																																																															
<b>29</b>	2NC	1NC																																																															
<b>30</b>	1NC	2NC																																																															
<b>33</b>	1NO+1NC																																																																
<b>34</b>	2NC																																																																
	without actuator (standard)																																																																
<b>F</b>	with straight actuator																																																																
<b>F1</b>	with right-angled actuator																																																																
<b>F2</b>	with jointed actuator																																																																
<b>F3</b>	with jointed actuator adjustable in two directions																																																																
<b>F7</b>	with jointed actuator adjustable in one direction																																																																
<b>F8</b>	with universal actuator																																																																
	no cable gland or connector (standard)																																																																
<b>K21</b>	with assembled cable gland suitable for Ø 6 to Ø 12 mm cables range																																																																
<b>K40</b>	with M12 metal connector assembled and wired, 8 poles (only for contact blocks 20, 21, 22, 28, 29, 30)																																																																
...	.....																																																																
	PG 13,5 (standard)																																																																
<b>M2</b>	M20x1,5																																																																
	silver contacts (standard)																																																																
<b>G</b>	silver contacts gold plated 1 µm																																																																



### Main data

- Metal housing or polymer housing, one conduit entry
- Protection degree IP67
- 9 contact blocks available
- 6 stainless steel actuators available
- M12 assembled connector versions
- Silver contacts gold plated versions
- Strong actuator locking (1000N)
- Manual actuator unlocking

### Markings and quality marks:



Approval IMQ:	EG605 (FD series) EG606 (FP series)
Approval UL:	E131787
Approval CCC:	2007010305230000 (FD series) 2007010305230014 (FP series)
Approval ECU:	1010151

### Housing

Housing type FP made of glass-reinforced polymer, self-extinguishing, shock-proof thermoplastic resin and with double insulation  $\square$

Housing type FD made of metal, coated with baked epoxy powder.

FD and FP series one conduit entry

Protection degree: IP67 (electrical contacts)

### General data

Ambient temperature:	from -25°C to +80°C
Version for operation in ambient temperature from -40°C to +80°C on request	
Max operating frequency:	3600 operations cycles <sup>1</sup> /hour
Mechanical endurance:	500.000 operations cycles <sup>1</sup>
Max actuating speed:	0,5 m/s
Min. actuating speed:	1 mm/s
Max holding force :	1000 N
Actuator extraction force:	30 N

(1) One operation cycle means two movements, one to close and one to open contacts, as foreseen by IEC 947-5-1 standard.

### Cross section of the conductors (flexible copper wire)

Contact blocks 20, 21, 22, 28, 29, 30:	min.	1 x 0,34 mm <sup>2</sup>	(1 x AWG 22)
	max.	2 x 1,5 mm <sup>2</sup>	(2 x AWG 16)
Contact blocks 18:	min.	1 x 0,5 mm <sup>2</sup>	(1 x AWG 20)
	max.	2 x 2,5 mm <sup>2</sup>	(2 x AWG 14)

### In conformity with standards:

IEC 60947-5-1, EN 60947-5-1, IEC 60204-1, EN 60204-1, EN 1088, EN ISO 12100-1, EN ISO 12100-2, IEC 529, EN 60529, NFC 63-140, VDE 0660-200, VDE 0113, CENELEC EN 50013, BG-GS-ET-15.

### Approvals:

IEC 60947-5-1, UL 508, GB14048.5-2001

### In conformity with requirements requested by:

Low Voltage Directive 2006/95/EC, Machinery Directive 2006/42/EC and Electromagnetic Compatibility 2004/108/EC.

### Positive contact opening in conformity with standards:

IEC 60947-5-1, EN 60947-5-1, VDE 0660-206.

**⚠ If not expressly indicated in this chapter, for the right installation and the correct utilization of all articles see requirements indicated from page 6/1 to page 6/8.**

### Electrical data

### Utilization categories

without connector	Thermal current (I <sub>th</sub> ):	10 A	Alternate current: AC15 (50...60 Hz)			
	Rated insulation voltage (U <sub>i</sub> ):	500 VAC 600 VDC	U <sub>e</sub> (V)	250	400	500
	28, 29, 30	400 VAC for contact blocks 20, 21, 22,	I <sub>e</sub> (A)	6	4	1
	Protection against short circuits:	fuse 10 A 500 V type aM	Direct current: DC13			
	Pollution degree:	3	U <sub>e</sub> (V)	24	125	250

I<sub>e</sub> (A) 6 1,1 0,4

with 4 or 5 poles M12 connector	Thermal current (I <sub>th</sub> ):	4 A	Alternate current: AC15 (50...60 Hz)			
	Rated insulation voltage (U <sub>i</sub> ):	250 VAC 300 VDC	U <sub>e</sub> (V)	24	120	250
	Protection against short circuits:	fuse 4 A 500 V type gG	I <sub>e</sub> (A)	4	4	4
	Pollution degree:	3	Direct current: DC13			
			U <sub>e</sub> (V)	24	125	250

I<sub>e</sub> (A) 4 1,1 0,4

with 8 poles M12 connector	Thermal current (I <sub>th</sub> ):	2 A	Alternate current: AC15 (50...60 Hz)			
	Rated insulation voltage (U <sub>i</sub> ):	30 VAC 36 VDC	U <sub>e</sub> (V)	24		
	Protection against short circuits:	fuse 2 A 500 V type gG	I <sub>e</sub> (A)	2		
	Pollution degree:	3	Direct current: DC13			
			U <sub>e</sub> (V)	24		

I<sub>e</sub> (A) 2

## Example of working cycle steps with FD 2899-F1

This type of switches **is applied on fences or protections where entrance is allowed to authorized personnel only. They have been studied to control large protected areas where operators may physically enter.** Supplied with a strong lock (up to 1000 N), the actuator can be removed from the head only after a complete rotation (180°) of the locking key. During the key rotation, electrical contacts are switched, and the actuator will be released only after NC contacts are positively opened. Contacts activated by the key locking device set to the initial position only with inserted actuator and with locking key device rotated in locked position. **It is impossible to rotate the key when the key locking device is unlocked and the actuator is removed (C state).** Contacts actuated by key locking or by actuator are available.

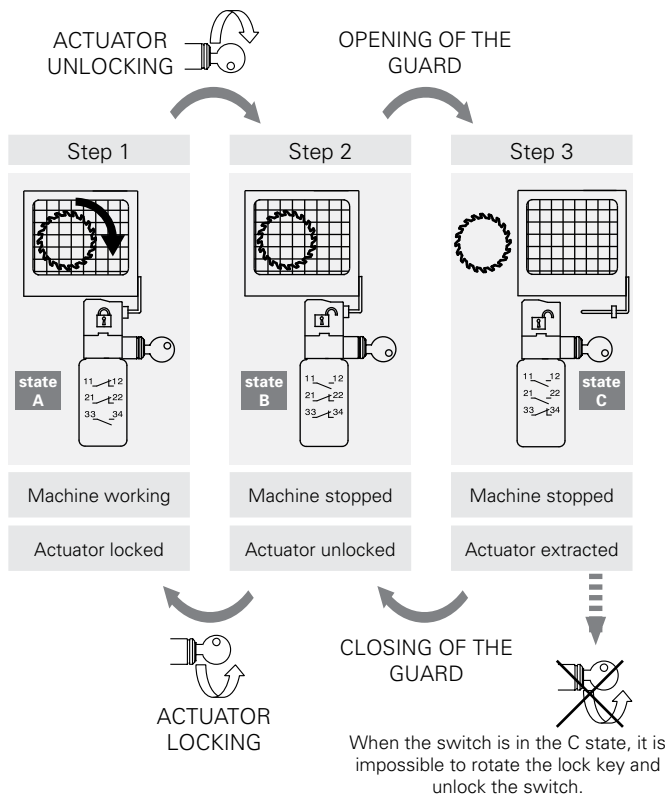

## Rotating head and release device

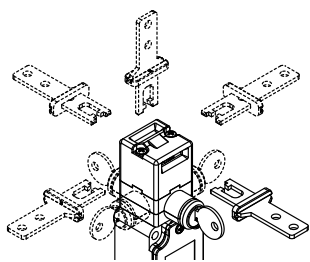

The head can be quickly rotated on each of the 4 sides of the switch by unfastening the two fixing screws. The release device can be rotated in 90° steps as well. This enables the switch to assume 32 different configurations.

## Limits of utilization

Do not use where dust and dirt may penetrate in any way into the head and deposit there, in particular where metal dust, concrete or chemicals are spread.  
Do not use where explosive or inflammable gas is present.

## Data type approved by IMQ, CCC and EZU

Rated insulation voltage (Ui): 500 VAC  
400 VAC for contact blocks 20, 21, 22, 28, 29, 30

Thermal current (Ith): 10 A

Protection against short circuits: fuse 10 A 500 V type aM

Protection degree: IP67

MV terminals (screw clamps)

Pollution degree 3

Utilization category: AC15

Operation voltage (Ue): 400 VAC (50 Hz)











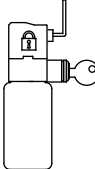
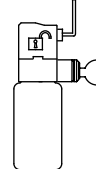
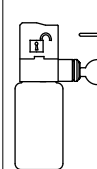









































Operation current (Ie): 3 A

Forms of the contact element: Zb, Y+Y, Y+Y+X, Y+Y+Y, Y+X+X

Positive opening of contacts on contact block 18, 20, 21, 22, 28, 29, 30

In conformity with standards: EN60947-1, EN 60947-5-1 and subsequent modifications and completions, fundamental requirements of the Low Voltage Directive 73/23 EEC and subsequent modifications and completions.

**Please contact our technical service for the list of type approved products.**

Operation state	state A	state B	state C
Actuator	Inserted and locked	Inserted and unlocked	Extracted
Lock	Closed	Opened	Opened
  			
<b>Contact blocks</b> FD 1899 1NC+1NO controlled by the lock FD 2099 2NC+1NO controlled by the lock FD 2199 3NC controlled by the lock FD 2299 1NC+2NO controlled by the lock FD 2899 1NO+1NC controlled by the lock 1NC controlled by the actuator FD 2999 2NC controlled by the lock 1NC controlled by the actuator FD 3099 1NC controlled by the lock 2NC controlled by the actuator	          	                   	                   

## Actuator regulation zone

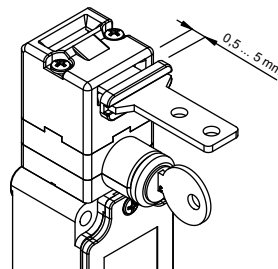

This switch has a wide backlash of the actuator into the head (4,5 mm) for an easier installation.  
With closed door, check that the actuator doesn't knock straight against the head of the switch; it must be in the adjustment zone (0,5...5 mm)

## Data type approved by UL

Utilization categories Q300 (69 VA, 125-250 VDC)  
A600 (720 VA, 120-600 VAC)

Data of the housing type 1, 4X (indoor use only), 12, 13

In conformity with standard: UL 508

For all contact blocks use 60 or 75 °C copper (Cu) conductor and wire size No. 12-14 AWG. Terminal tightening torque of 7,1 Lb-In.

**Please contact our technical service for the list of type approved products.**

Dimensional drawings

		polymer housing	metal housing
		Switch without actuator supplied with two keys	Switch without actuator supplied with two keys
Contacts type:			
L = slow action			
Contact blocks			
18	L	FP 1899 → 1NO+1NC	FD 1899 → 1NO+1NC
20	L	FP 2099 → 1NO+2NC	FD 2099 → 1NO+2NC
21	L	FP 2199 → 3NC	FD 2199 → 3NC
22	L	FP 2299 → 2NO+1NC	FD 2299 → 2NO+1NC
28	L	FP 2899 → 1NO+2NC	FD 2899 → 1NO+2NC
29	L	FP 2999 → 3NC	FD 2999 → 3NC
30	L	FP 3099 → 3NC	FD 3099 → 3NC
33	L	FP 3399 → 1NO+1NC	FD 3399 → 1NO+1NC
34	L	FP 3499 → 2NC	FD 3499 → 2NC
Min. force		30 N (40 N →)	30 N (40 N →)

How to read travel diagrams

All measures in the diagrams are in mm or in degrees

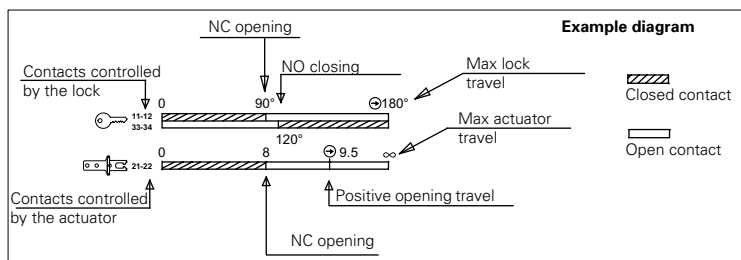

IMPORTANT:

NC contacts (↔) has to be considered with inserted and blocked actuator in the key lock. **In safety applications** it is necessary to activate the switch **at least up to the positive opening point** indicated in the diagrams with the symbol ⊕. Operate the switch **at least with the positive opening force**, indicated between brackets, below each article, next the value of minimum force.

## Stainless steel actuators

10 pcs packs

**IMPORTANT:** These actuators must be used with FD, FP, FL, FC or FS series only (e.g. FD 693)

Article	Description
VF KEYF	Straight actuator

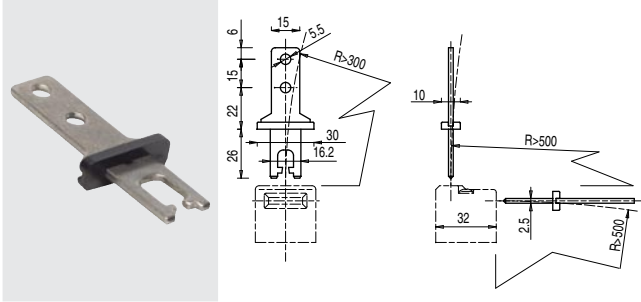

Article	Description
VF KEYF1	Right-angled actuator

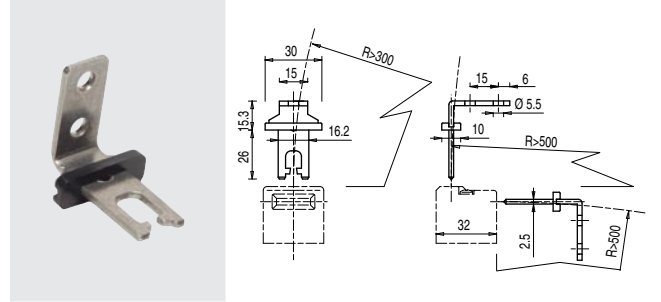

Article	Description
VF KEYF2	Jointed actuator

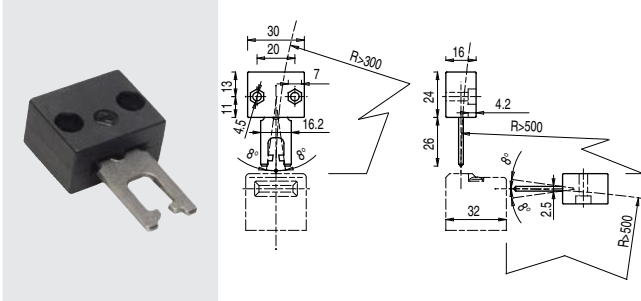

The actuator can flex in four directions for applications where the door alignment is not precise

Article	Description
VF KEYF3	Jointed actuator adjustable in two directions

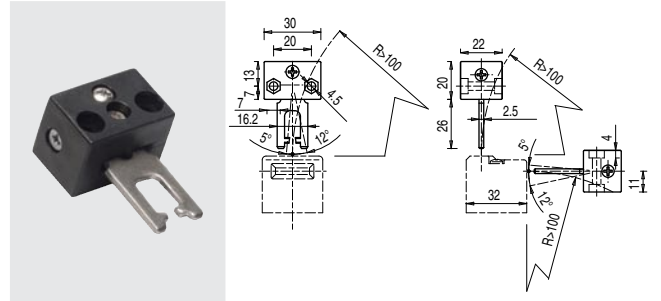

Actuator adjustable in two directions for doors with reduced dimensions.

Article	Description
VF KEYF7	Jointed actuator adjustable in one direction

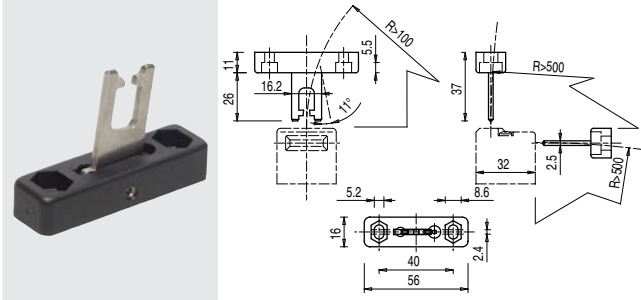

Actuator adjustable in one direction for doors with reduced dimensions.

Article	Description
VF KEYF8	Universal actuator

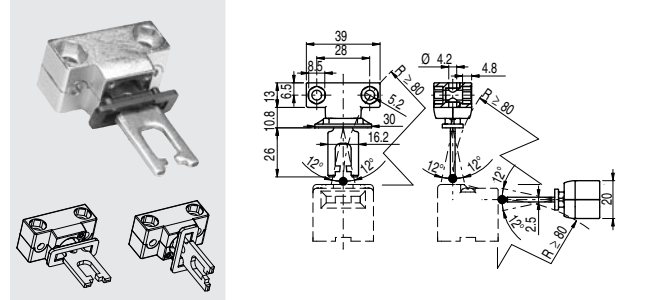

Jointed and two directions adjustable actuator for doors with reduced dimensions. The actuator has two couples of fixing holes and it is possible to rotate the actuator-working plan (see picture).

## Accessories

Article	Description
VF KB1	Actuator entry locking device



Padlockable device to lock the actuator entry in order to prevent from the accidental closing of the door behind operators while they are inside the machine. To be used only with FD, FL, FC and FS series with metal heads.



Article	Description
VF KLA371	Set of 2 locking keys

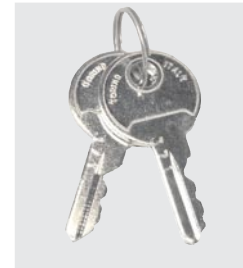

Extra copy of the locking keys to be purchased if further keys are needed (standard supply 2 units). All switches keys have the same code. Other codes on request.

Accessories See page 5/1

Items with code on the **green** background are available in stock