

Selection diagram

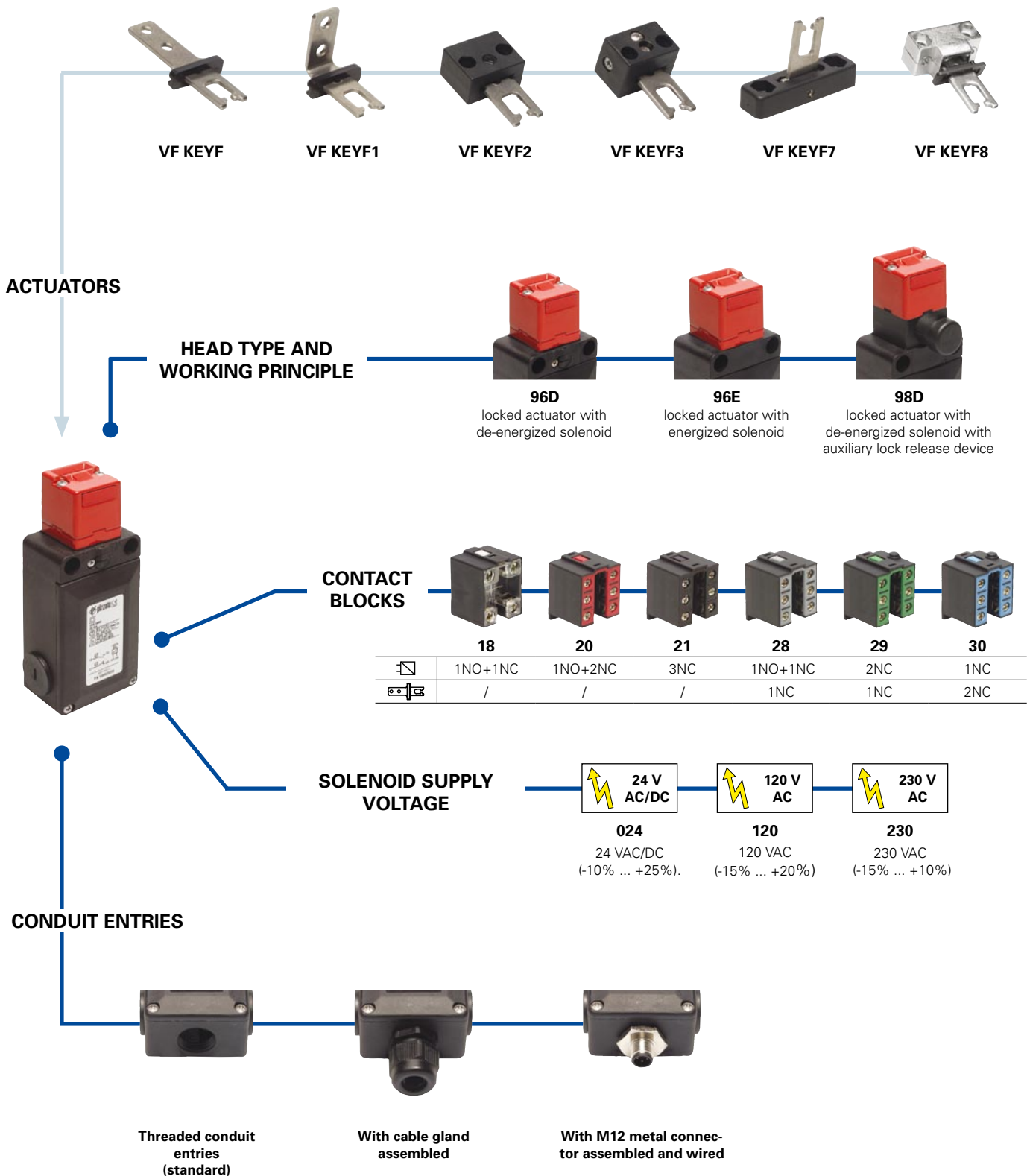

● product option
 → accessory sold separately

Code structure

Attention! The feasibility of a code number does not mean the effective availability of a product. Please contact our sales office.

article
options

FS 1896D024-F1GM2K40

Contact blocks

	Solenoid operated	Actuator operated
18	1NO+1NC	
20	1NO+2NC	
21	3NC	
28	1NO+1NC	1NC
29	2NC	1NC
30	1NC	2NC

Working principle

96D	locked actuator with de-energized solenoid
96E	locked actuator with energized solenoid
98D	locked actuator with energized solenoid with auxiliary lock release device

Solenoid supply voltage

024	24 VAC/DC (-10% ... +25%).
120	120 VAC (-15% ... +20%)
230	230 VAC (-15% ... +10%)

Preinstalled cable gland or connectors

	no cable gland or connector (standard)
K21	with assembled cable gland suitable for Ø 6 to Ø 12 mm cables range
K40	with M12 metal connector assembled and wired, 8 poles
...

For the complete list of all combinations, please contact our technical office.

Threaded conduit entry

	PG 13,5 (standard)
M2	M20x1,5

Contacts type

	silver contacts (standard)
G	silver contacts gold plated 1 µm

Actuators

	without actuator (standard)
F	with straight actuator
F1	with right-angled actuator
F2	with jointed actuator
F3	with jointed actuator adjustable in two directions
F7	with jointed actuator adjustable in one direction
F8	with universal actuator



Main data

- Polymer housing, three conduit entries
- Protection degree IP66
- 6 contact blocks available
- 6 stainless steel actuators available
- Three supply voltages available
- Versions with auxiliary release device or auxiliary lock release device
- Versions with energized or de-energized solenoid

Markings and quality marks:



Approval IMQ: CA02.00792
 Approval UL: E131787
 Approval CCC: 2007010305230011
 Approval ECU: 1010151

Notes: Calculate the power supply using the average solenoid power. Please consider the inrush solenoid power in order to avoid intervention of overload-protection in case of electronic power supply.

Technical data

Housing

Housing made of glass-reinforced polymer, self-extinguishing, shock-proof thermoplastic resin and with double insulation

Three conduit entries

Protection degree: IP66 (electrical contacts)

General data

Ambient temperature: from -25°C to +60°C
 Max operating frequency: 600 operations cycles¹/hour
 Mechanical endurance: 800.000 operations cycles¹
 Max actuating speed: 0,5 m/s
 Min. actuating speed: 1 mm/s
 Max holding force: 1100 N (head 96), 900 N (head 98)
 Max backlash of the actuator: 4,5 mm
 Actuator extraction force: 30 N

(1) One operation cycle means two movements, one to close and one to open contacts, as foreseen by IEC 947-5-1 standard.

Cross section of the conductors (flexible copper wire)

Contact blocks 20, 21, 28, 29, 30:	min.	1 x 0,34 mm ²	(1 x AWG 22)
	max.	2 x 1,5 mm ²	(2 x AWG 16)
Contact blocks 18:	min.	1 x 0,5 mm ²	(1 x AWG 20)
	max.	2 x 2,5 mm ²	(2 x AWG 14)

In conformity with standards:

IEC 60947-5-1, EN 60947-5-1, IEC 60204-1, EN 60204-1, EN 1088, EN ISO 12100-1, EN ISO 12100-2, IEC 529, EN 60529, EN 61000-6-2, EN 61000-6-3, NFC 63-140, VDE 0660-200, VDE 0113, CENELEC EN 50013, BG-GS-ET-15.

Approvals:

IEC 60947-5-1, UL 508, GB14048.5-2001

In conformity with requirements requested by:

Low Voltage Directive 2006/95/EC, Machinery Directive 2006/42/EC and Electromagnetic Compatibility 2004/108/EC.

Positive contact opening in conformity with standards:

IEC 60947-5-1, EN 60947-5-1, VDE 0660-206.

Solenoid

Solenoid duty cycle: 100% ED
 Inrush solenoid power: 56 VA (0,1 s / 0,05 s for 230 V)
 Steady-state solenoid power: 4 VA
 Average solenoid power: 20 VA
 Solenoid protection 24 V: fuse 1 A type aM
 Solenoid protection 120 V: fuse 630 mA, delayed type
 Solenoid protection 230 V: fuse 315 mA, delayed type

⚠ If not expressly indicated in this chapter, for the right installation and the correct utilization of all articles see requirements indicated from page 6/1 to page 6/8.

Electrical data

Utilization categories

without connector
 Thermal current (I_{th}): 10 A
 Rated insulation voltage (U_i): 500 VAC 600 VDC
 400 VAC for contact blocks 20, 21, 28, 29, 30
 Protection against short circuits: fuse 10 A 500 V type aM
 Pollution degree: 3

Alternate current: AC15 (50...60 Hz)			
U _e (V)	250	400	500
I _e (A)	6	4	1
Direct current: DC13			
U _e (V)	24	125	250
I _e (A)	6	1,1	0,4

with 8 poles M12 connector
 Thermal current (I_{th}): 2 A
 Rated insulation voltage (U_i): 30 VAC 36 VDC
 Protection against short circuits: fuse 2 A 500 V type gG
 Pollution degree: 3

Alternate current: AC15 (50...60 Hz)	
U _e (V)	24
I _e (A)	2
Direct current: DC13	
U _e (V)	24
I _e (A)	2

Example of working cycle steps with FS 2896D024-F1 (switch with working principle D)

These switches are used on machines where the hazardous conditions remain for a while, even after the machine has been switched off, for example because of mechanical inertia of pulleys, saw disks, parts under pressure or with high temperatures. They can also be used when it is necessary to control machine guards, allowing the opening of protections only under specific conditions.

Rotating head and release device

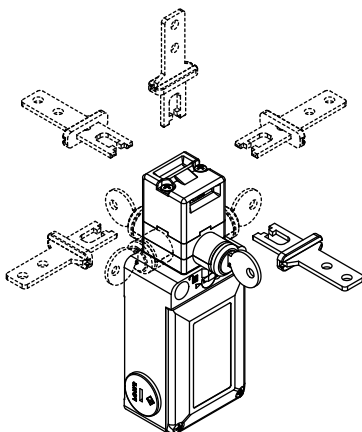

The head can be quickly rotated on each of the 4 sides of the switch by unfastening the two fixing screws. The mechanical lock release device can be rotated in 90° steps as well. This enables the switch to assume 32 different configurations.

Actuator regulation zone

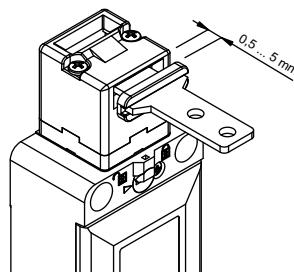

This switch has a wide back-lash of the actuator into the head (4,5 mm) to avoid that door gaskets keep in traction the actuator on the solenoid. With closed door, check that the actuator doesn't knock straight against the head of the switch; it must be in the adjustment zone (0,5...5 mm)

Actuator holding force

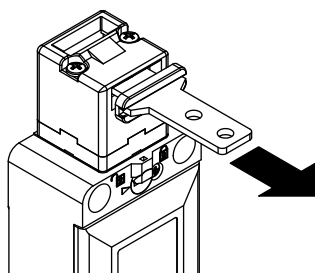

Thanks to recent mechanical improvement the strong interlocking system guarantees a maximum actuator holding force of 1100 N (head 96).

Limits of utilization

Do not use where dust and dirt may penetrate in any way into the head and deposit there, in particular where metal dust, concrete or chemicals are spread.

Do not use where explosive or inflammable gas is present.

Installation of two or more switches connected to the same power supply

24 VAC/DC version only

- This operation is intended to reduce the results of the solenoid inrush current on the power supply and has to be executed only if necessary and with special care.
- Switch off the power supply.
- Open the switch cover.
- Remove the black plastic protection that covers the solenoid by unscrewing the two screws which fix the protection to the body of the switch.
- Move the dip-switch with a tool so that each switch has a different combination (see figure beside). If more than four switches are installed, repeat the combinations for any next set of four switches.
- Reposition the black plastic protection and tighten the two screws with a torque of 0,8 Nm.

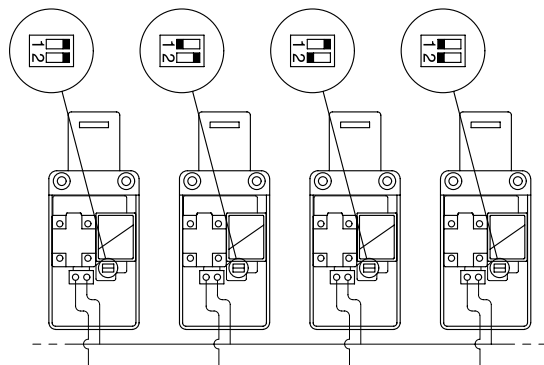

Data type approved by IMQ, CCC and EZU

Rated insulation voltage (Ui): 500 VAC
400 VAC for contact blocks 20, 21, 28, 29, 30

Thermal current (Ith): 10 A

Protection against short circuits: fuse 10 A 500 V type aM

Protection degree: IP66

MV terminals (screw clamps)

Pollution degree 3

Utilization category: AC15

Operation voltage (Ue): 400 VAC (50 Hz)

Operation current (Ie): 3 A

Forms of the contact element: Zb, Y+Y+X, Y+Y+Y, Y+X+X

Positive opening of contacts on contact block 18, 20, 21, 28, 29, 30

In conformity with standards: EN60947-1, EN 60947-5-1 and subsequent modifications and completions, fundamental requirements of the Low Voltage Directive 73/23 EEC and subsequent modifications and completions.

Data type approved by UL

Utilization categories Q300 (69 VA, 125-250 VDC)
A600 (720 VA, 120-600 VAC)

Data of the housing type 1, 4X (indoor use only), 12, 13

In conformity with standard: UL 508

For all contact blocks use 60 or 75 °C copper (Cu) conductor and wire size No. 12-14 AWG. Terminal tightening torque of 7,1 Lb-In.

Please contact our technical service for the list of type approved products.

Please contact our technical service for the list of type approved products.

Description

The working principle of these safety switches allows three different working states:

state A: with the actuator inserted and blocked by the solenoid

state B: with the actuator inserted but not blocked

state C: with the actuator extracted

All or some of these states may be controlled through the positive opening contacts of the internal contact block. In detail, contact blocks that have electric contacts marked with the symbol of the solenoid (☐) are switched in the transition between the state A and state B, while the electric contacts marked with the symbol of the actuator (☐) are switched between state B and state C:

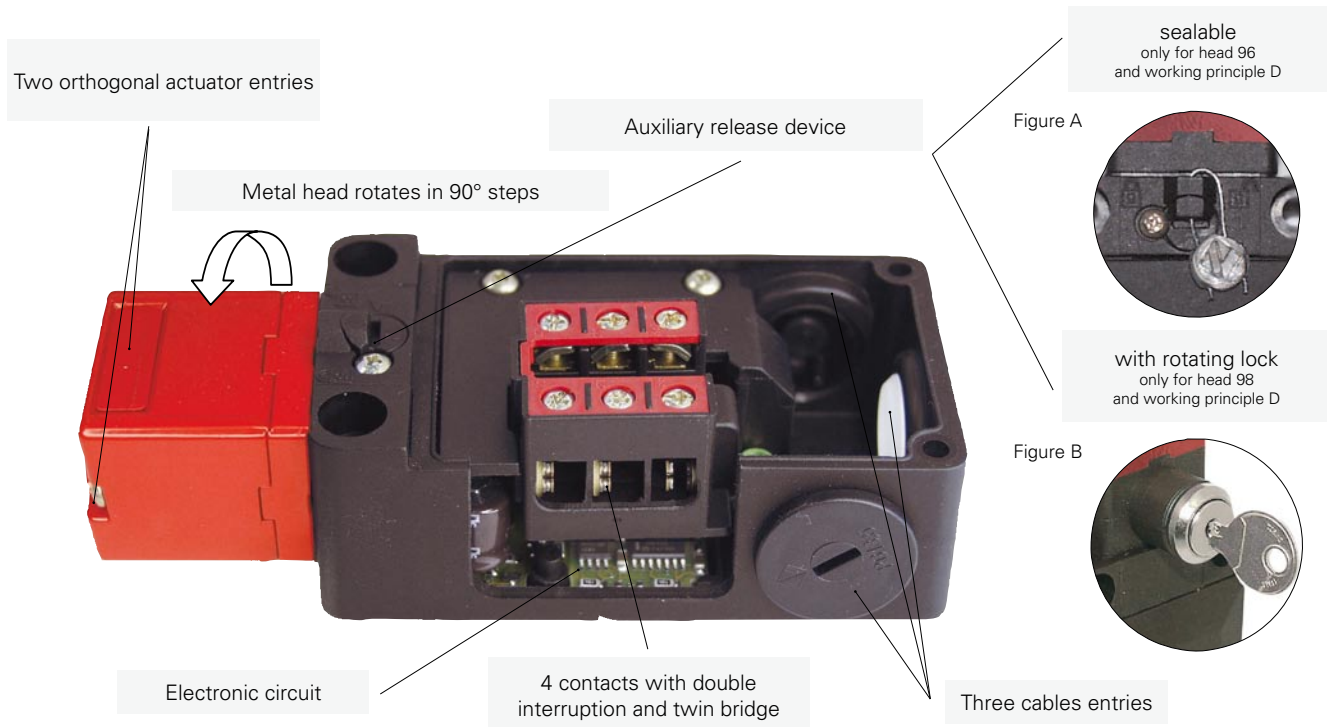

It is also possible to choose between two working principles for the actuator locking:

- **Working principle D**: Actuator blocked with de-energized solenoid. Actuator release is obtained by power supply to the solenoid (see example of working cycle steps).
- **Working principle E**: Actuator blocked with energized solenoid. The unlock of the actuator is obtained by power-off to the solenoid. It is advisable to use this version under special conditions because a blackout will allow the immediate opening of the protection.

This series of products includes many technical solutions that result flexible on installation and easy working:

- Six different types of stainless steel actuator, suitable to be fixed in several positions and with insertion radius arc equal to or over 80 mm.
- Swinging head, in 90° steps, with two actuator entries for easy installation of the switch.
- To extract the inserted but not blocked actuator, a 30 N force is necessary, that avoids the guard opening because of vibrations or impacts.
- When actuator is locked, it can still move a little (4,5 mm), to avoid that door gaskets keep in traction the actuator on the solenoid.
- Housing with three conduit entries for an easier installation or connection in series.
- Electronic control of the power supply, which allow a wide tolerance on supply voltage. This technical solution resolves the problems that may derive from not stable power supply (machine distance from main transformers, tension variation between night/day hours), allowing also a low solenoid power consumption and consequently enlarging the working temperatures range of the switch.
- No-loosing screws contact blocks, fingers protection, twin bridge contacts and double interruption for a higher contact reliability.

Versions with D working principle are supplied with a sealable auxiliary release device used by technicians during the installation or to access to inside the machine in case of black-out. The release device may be of sealable type (head 96, see figure A) or lock type (head 98, see figure B). In this last case the release device may also be used to allow authorized operators in possession of key to open small protections.

Attention! These switches alone are not suitable for applications where operators with key may physically enter the dangerous area, because an eventual closing of the door behind them could restart the machine working. In this case must be used the entry locking device VF KB1 that is visible on page 4/63.

Example of working cycle steps with FS 2896D024-F1 (switch with working principle D)

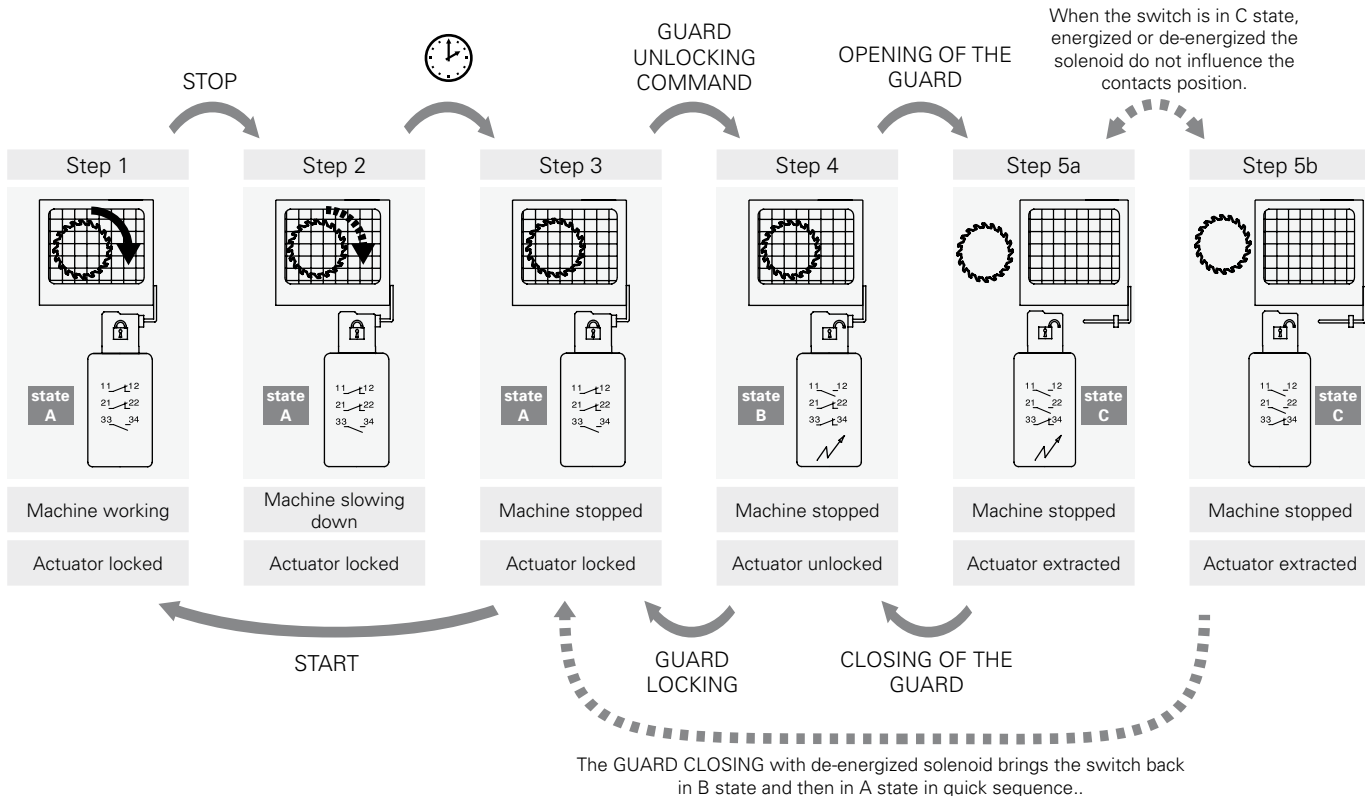

Contacts position in switch states

Operation state	Working principle D locked actuator with de-energized solenoid			Working principle E locked actuator with energized solenoid		
	state A	state B	state C	state A	state B	state C
Actuator	Inserted and locked	Inserted and unlocked	Extracted	Inserted and locked	Inserted and unlocked	Extracted
Solenoid	De-energized	Energized	-	Energized	De-energized	-
FS 18..... 1NC+1NO controlled by the solenoid	11 / 12 23 / 24	11 / 12 23 / 24	11 / 12 23 / 24	11 / 12 23 / 24	11 / 12 23 / 24	11 / 12 23 / 24
FS 20..... 2NC+1NO controlled by the solenoid	11 / 12 21 / 22 33 / 34	11 / 12 21 / 22 33 / 34	11 / 12 21 / 22 33 / 34	11 / 12 21 / 22 33 / 34	11 / 12 21 / 22 33 / 34	11 / 12 21 / 22 33 / 34
FS 21..... 3NC controlled by the solenoid	11 / 12 21 / 22 31 / 32	11 / 12 21 / 22 31 / 32	11 / 12 21 / 22 31 / 32	11 / 12 21 / 22 31 / 32	11 / 12 21 / 22 31 / 32	11 / 12 21 / 22 31 / 32
FS 28..... 1NO+1NC controlled by the solenoid 1NC controlled by the actuator	11 / 12 21 / 22 33 / 34	11 / 12 21 / 22 33 / 34	11 / 12 21 / 22 33 / 34	11 / 12 21 / 22 33 / 34	11 / 12 21 / 22 33 / 34	11 / 12 21 / 22 33 / 34
FS 29..... 2NC controlled by the solenoid 1NC controlled by the actuator	11 / 12 21 / 22 31 / 32	11 / 12 21 / 22 31 / 32	11 / 12 21 / 22 31 / 32	11 / 12 21 / 22 31 / 32	11 / 12 21 / 22 31 / 32	11 / 12 21 / 22 31 / 32
FS 30..... 1NC controlled by the solenoid 2NC controlled by the actuator	11 / 12 21 / 22 31 / 32	11 / 12 21 / 22 31 / 32	11 / 12 21 / 22 31 / 32	11 / 12 21 / 22 31 / 32	11 / 12 21 / 22 31 / 32	11 / 12 21 / 22 31 / 32

Dimensional drawings

Contacts type:		Switch with D working principle, supplied with sealable auxiliary release device and without actuator	Switch with E working principle and without actuator	Switch with D working principle, supplied with lock auxiliary release device and without actuator
[L] = slow action				
Contact blocks				
18	[L] FS 1896D024 → 1NO+1NC		FS 1896E024 → 1NO+1NC	FS 1898D024 → 1NO+1NC
20	[L] FS 2096D024 → 1NO+2NC		FS 2096E024 → 1NO+2NC	FS 2098D024 → 1NO+2NC
21	[L] FS 2196D024 → 3NC		FS 2196E024 → 3NC	FS 2198D024 → 3NC
28	[L] FS 2896D024 → 1NO+2NC		FS 2896E024 → 1NO+2NC	FS 2898D024 → 1NO+2NC
29	[L] FS 2996D024 → 3NC		FS 2996E024 → 3NC	FS 2998D024 → 3NC
30	[L] FS 3096D024 → 3NC		FS 3096E024 → 3NC	FS 3098D024 → 3NC
Min. force		30 N (40 N →)	30 N (40 N →)	30 N (40 N →)

How to read travel diagrams

All measures in the diagrams are in mm

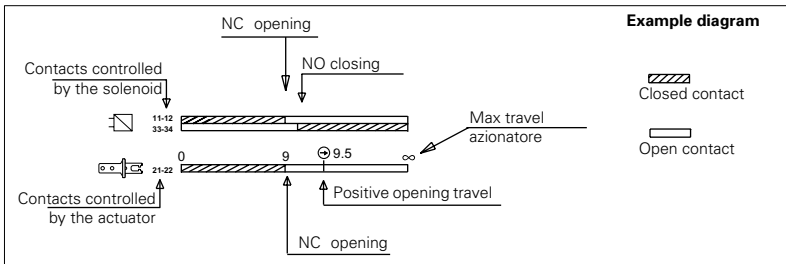

IMPORTANT:

NC contact has to be considered with inserted actuator and lock. In safety applications it is necessary to activate the switch **at least up to the positive opening point** indicated in the diagrams with the symbol ⊕. Operate the switch **at least with the positive opening force**, indicated between brackets, below each article, next the value of minimum force.

Accessories

Article	Description
VF KB1	Actuator entry locking device



Padlockable device to lock the actuator entry in order to prevent from the accidental closing of the door behind operators while they are inside the machine. To be used only with FD, FL, FC and FS series with metal heads.



Article	Description
VF KLA371	Set of 2 locking keys

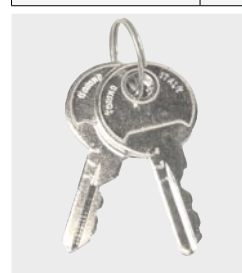

Extra copy of the locking keys to be purchased if further keys are needed (standard supply 2 units). All switches keys have the same code. Other codes on request.

Stainless steel actuators

10 pcs packs

IMPORTANT: These actuators must be used with FD, FP, FL, FC or FS series only (e.g. FS 1896D024)

Article	Description
VF KEYF	Straight actuator

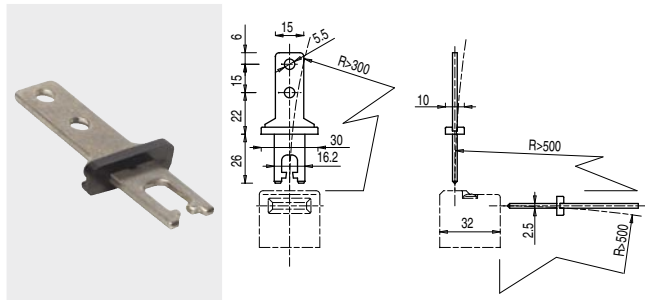

Article	Description
VF KEYF1	Right-angled actuator

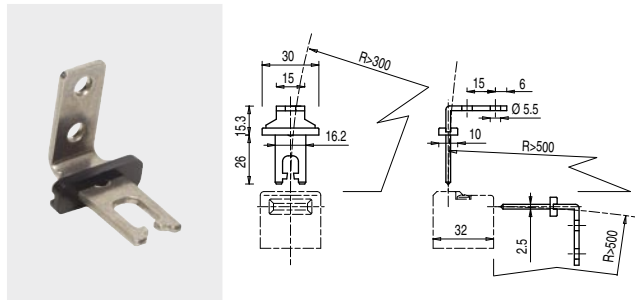

Article	Description
VF KEYF2	Jointed actuator

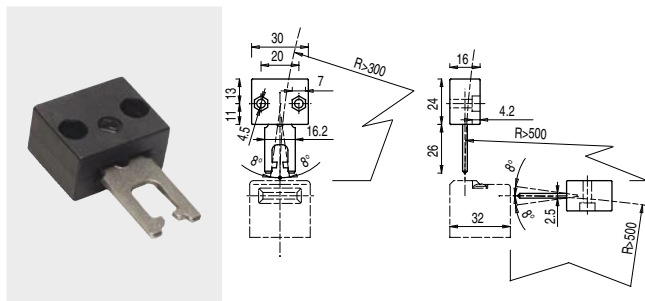

The actuator can flex in four directions for applications where the door alignment is not precise

Article	Description
VF KEYF3	Jointed actuator adjustable in two directions

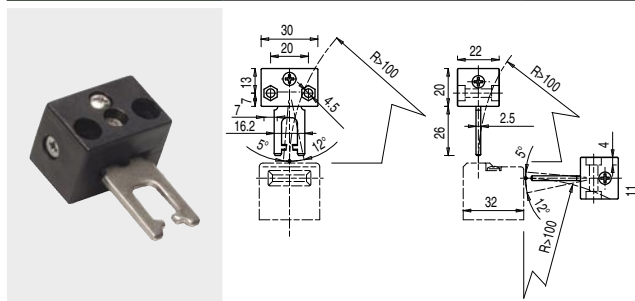

Actuator adjustable in two directions for doors with reduced dimensions.

Article	Description
VF KEYF7	Jointed actuator adjustable in one direction

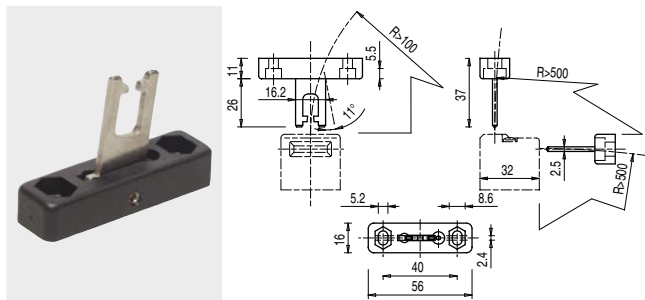

Actuator adjustable in one direction for doors with reduced dimensions.

Article	Description
VF KEYF8	Universal actuator

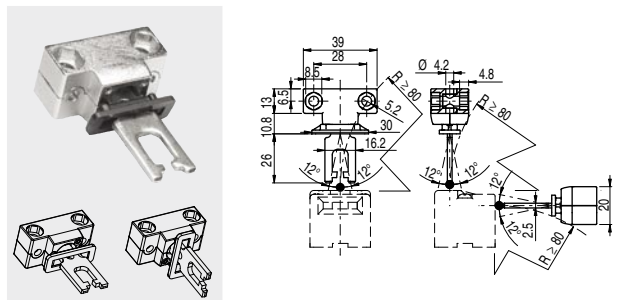

Jointed and two directions adjustable actuator for doors with reduced dimensions. The actuator has two couples of fixing holes and it is possible to rotate the actuator-working plan (see picture).

Accessories for sealing



Pliers, steel wire and lead seals used to seal the auxiliary release device (head 96D).

Article	Description
VF FSPB-200	Set of 200 lead seals
VF FSPB-10	Set of 10 lead seals

Article	Description
VF FSFI-400	400 m steel wire roll
VF FSFI-10	10 m steel wire roll

Article	Description
VF FSPZ	Plier without logo

Accessories See page 5/1

Items with code on the **green** background are available in stock