



RAYLEIGH INSTRUMENTS LIMITED

Raytel House · Brook Road · Rayleigh · Essex SS6 7XH
Tel: (01268) 749300 · Fax: (01268) 749309
Internet: <http://www.rayleigh.co.uk>
e-mail: sales@rayleigh.co.uk

Isolated smart signal conditioner

E&OE

DAT 4135

FEATURES

RTD, TC, mV, V, mA, Resistor and Potentiometer input
Voltage and current output
Galvanically isolated
Configurable by Personal Computer
High accuracy and performance's stability
On-field reconfigurable
In compliance with EMC standards - CE Mark
DIN rail mounting
Available as configured device on user specifications

APPLICATIONS

Temperature Monitoring and Control for:
- Process Controls
- Automation Systems
- Energy sources management



GENERAL INFORMATION

Introduction

The DAT 4135 is a "smart" conditioner capable to perform many functions such as: Linearized temperature measurement with thermocouple or RTD sensors. Conversion of a linear resistance variation to a standard analog current or voltage signal. Conversion of a voltage signal, even coming from a potentiometer connected to its input, to a current or voltage linearized signal. Its very thin profile allows to mount a "smart" conditioner with galvanic isolation even at a pitch of only 12.5 mm on the DIN rail.

General

The device is built around a microprocessor core which controls any device function in a continuous and reliable mode by an efficient program developed by DATEXEL. The unit can be configured to accept input from a wide range of sensors and electrical parameters and to supply in the output a current or voltage signal. Thanks to its versatility of use, it greatly reduces the warehouse stock satisfying a wide variety of needs; thus it offers immediate and evident economical advantages. By means of its continuous self calibrating operation, controlled by the microprocessor, the device guarantees an excellent accuracy and very stable measurement, both in time and in the operating temperature. Further, with this operating mode, the device is not longer subject to the usual variations of the circuit parameters. The 2000 Vac galvanic isolation, removing all ground loop effects as the input is electrically and physically isolated from the loop power supply, allows the use of the conditioner even in the heavy environmental conditions found in the industrial applications. The units are manufactured by using high quality and high precision electronic components which are assembled by the SMD technology; Both of these elements are the indispensable tools to realize a very reliable device. The DAT 4135, developed, manufactured and tested in strict accordance with the quality assurance standard ISO 9001 / EN 29001, is in compliance with the directive 89/336/CEE on the electromagnetic compatibility and the CE mark confirms the compliance of the product. The device is housed in a rough self extinguish plastic container suitable for mounting on DIN rails.

Input types

The DAT 4135 is configurable for any of the following input types:

- **RTD** input for linearised PT100, PT1000, Ni100 and Ni1000. The cable compensation is possible by 3 or 4 wire connection.
- **Thermocouple** input for 8 different types. The Cold Junction Compensation is selectable as internal or external.
- **Current** input from -10 to +24 mA.
- **Voltage** input up to -400/+700 mV or up to +/-10 V
- **Resistance** input for linear resistance measurement from 20 Ohm to 2 KOhm with 3 or 4 wire compensation.
- **Potentiometer** input from 20 Ohm to 50 KOhm.

Output

Programmable current or voltage output in the 0 to 20 mA or 0 to 10 v range. Programmable Sensor Burnout as "Upscale" or "Downscale". Short circuit protection is provided on the output.

Set-Up

All the configurable functions and parameters are easily programmed by means of a PC with a software package, named PROSOFT, developed by DATEXEL. This "guide lines menu" type program operates under "Windows95TM" on a PC which communicate, via an interface adapter, with the DAT 4135. The adapter is connected through a cable to an apposite connector situated on the conditioner (for more detailed information, see the figure in the next page).
IMPORTANT: On request the transmitter can be supplied configured for the desired sensor type and calibrated for the specific range as defined in the order (see "HOW TO ORDER ").

DAT 4135 BLOCK AND WIRING DIAGRAM

E&OE

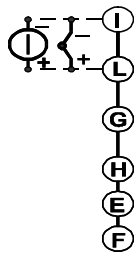
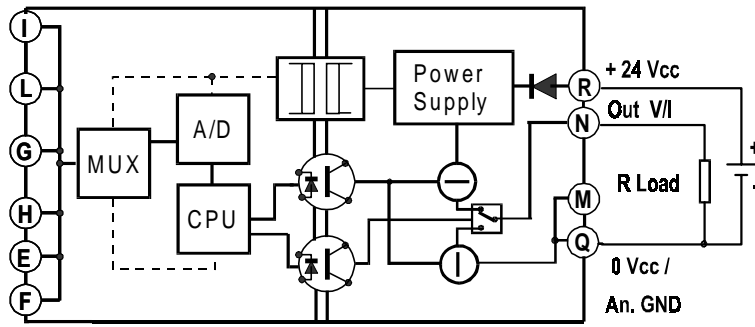

mV / TC

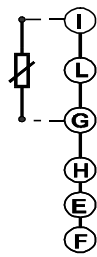

RTD/RES 2 WIRE

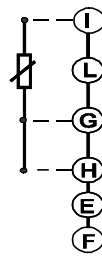

RTD/RES 3 WIRE

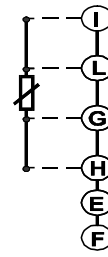

RTD/RES 4 WIRE

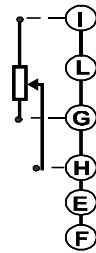

POTENTIOMETER

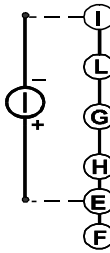

Volt

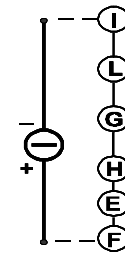

mA

CONFIGURATION

This operation is carried out, using a Personal Computer with "Windows95™" operating system, by the software PROSOFT, specifically developed by DATEXEL, and by the interfacing adapter PRODAT-03.

The software includes a window-type program by which the operator is guided through the operations to be executed. Once the data are inputted, a few seconds is the time necessary to complete a configuration cycle, while the time necessary for the introduction of data is some ten of seconds.

The parameters which is possible to configure are illustrated in the "Configuration Scheme" in the page here at side. Furthermore it is possible, in the same phase, to program the "zero" and the "full scale" values. The calibration of the device is made automatically, with the maximum accuracy, without the need of any mechanical regulation. The configuration is normally made at the factory in conformity to the customer's order or, alternatively, in one of the most used configuration: DAT4135 / Pt100-0..200°C / S.L. / 3-wire / 4..20mA / Upscale.

The device can be reconfigured and reprogrammed for any number of time. This operation is possible also when the device is operating in the plant or in the field because it is possible, by software, to interrupt momentarily the normal operation which restarts automatically after the configuration.

The complete configuration system (which includes: interface module PRODAT-03 and software) is supplied from DATEXEL at economical price.



DAT 4135

PRODAT-03

DAT 4135 Technical Specifications

(typical @ 25°C and in the nominal conditions)

Input

RTD			
Input	Min	Max	Span Min
PT100	-200°C	850°C	50°C
PT1000	-200°C	200°C	50°C
NI100	-60°C	180°C	50°C
NI1000	-60°C	150°C	50°C

TC			
Input	Min	Max	Span Min
J	-200°C	1200°C	2 mV
K	-200°C	1370°C	2 mV
S	-50°C	1760°C	2 mV
R	-50°C	1760°C	2 mV
B	400°C	1820°C	2 mV
E	-200°C	1000°C	2 mV
T	-200°C	400°C	2 mV
N	-200°C	1300°C	2 mV

Voltage			
Input	Min	Max	Span Min
mV	-100	+700	2 mV
mV	-400	+400	2 mV
V	-10V	+10V	500 mV

Potentiometer			
Range	Min	Max	Span Min
Ohm	20	200	10%
Ohm	200	500	10%
KOhm	0.50	50	10%

Resistance			
Input	Min	Max	Span Min
Low	20 Ohm	300 Ohm	10 Ohm
High	300 Ohm	2000 Ohm	200 Ohm

Current			
Input	Min	Max	Span Min
mA	-10mA	+24 mA	2 mA

Input impedance

TC, mV >=10 MOhm
V >= 1 MOhm
Current ~50 Ohm

Lead wire resistance influence

TC, mV, V </=0.8uV/Ohm
RTD 3-wire 0.05%/Ohm (50 Ohm max) (2)
RTD 4-wire 0.005%/Ohm (100 Ohm max)

RTD Sensor Current

Typical 0.350 mA

E&OE

Output

Current Output

Signal range (0/4 - 20 mA) or (20 - 4/0 mA)
Load Resistance 650 Ohm max.

Voltage Output

Signal range (0 - 5/10 V) or (10/5 - 0 V)
Load Resistance 3.5 K Ohm min.
Short circuit current 20 mA approx.

Accuracy

Linearity
TC ±0.2 % (1)
RTD ±0.1 % (1)

Calibration

RTD The larger of ±0.1%(1) and ±0.2 °C
Res. Low The larger of ±0.1%(1) and ±0.15 Ohm
Res. High The larger of ±0.2%(1) and ±1 Ohm
mV, TC The larger of ±0.1%(1) and ±18 uV
V The larger of ±0.1%(1) and ±2 mV
Input current The larger of ±0.1%(1) and ±6 uV
Cold junction comp. ±0.5 °C
Output current ±7 uA
Output voltage ±5 mV

Thermal Drift

Full Scale ±0.01%/°C
Cold junction Compensation ±0.01%/°C

Common data

Supply
Supply Voltage 18 - 30 Vdc
Supply current 40 mA at 24 Vdc
Isolation Voltage 2000 Vac for 60 Sec
Polarity protected 60 Vdc

Temperature & Humidity

Ambient Temperature -20 °C to +70 °C
Humidity (not condensig) 0 to 90%

EMC

Emission EN50081-2
Immunity EN50082-2
RF Immunity tested for 10V/m up to 1000MHz

Response time

Rise time(10 - 90 %) 0,4 sec. approx.

Housing

Material Selfextinguish plastic
Mounting DIN B head or bigger
Weight Approx. 50 g

Note:(1) of input span
(2) Balancing required

RI06035