



RAYLEIGH INSTRUMENTS LIMITED

Raytel House · Brook Road · Rayleigh · Essex SS6 7XH
Tel: (01268) 749300 · Fax: (01268) 749309
Internet: <http://www.rayleigh.co.uk>
e-mail: sales@rayleigh.co.uk

Two-wire smart transmitter

E&OE

DAT 2015

FEATURES

RTD, TC, mV, V, mA, Resistor and Potentiometer input
Configurable by Personal Computer
High accuracy and performance's stability
On-field reconfigurable
In compliance with EMC standards - CE Mark
DIN rail mounting
Available as configured device on user specifications

APPLICATIONS

Temperature Monitoring and Control for:

- Process Controls
- Automation Systems
- Energy sources management



GENERAL INFORMATION

Introduction

The DAT 2015 is a "smart" transmitter capable to perform many functions such as: Linearized temperature measurement with thermocouple or RTD sensors. Conversion of a linear resistance variation to a standard analog current of 4-20 mA. Conversion of a voltage signal, even coming from a potentiometer connected to its input, to a 4-20 mA linearized signal. Its very thin profile allows to mount a "smart" transmitter even at a pitch of only 12.5 mm on the DIN rail.

General

The device is built around a microprocessor core which controls any device function in a continuous and reliable mode by an efficient program developed by DATEXEL. The unit can be configured to accept input from a wide range of sensors and electrical parameters. Thanks to its versatility of use, it greatly reduces the warehouse stock satisfying a wide variety of needs; thus it offers immediate and evident economical advantages. By means of its continuous self calibrating operation, controlled by the microprocessor, the device guarantees an excellent accuracy and very stable measurement, both in time and in the operating temperature. Further, with this operating mode, the device is not longer subject to the usual variations of the circuit parameters.

The units are manufactured by using high quality and high precision electronic components which are assembled by the SMD technology; Both of these elements are the indispensable tools to realize a very reliable device. The DAT 2015, developed, manufactured and tested in strict accordance with the quality assurance standard ISO 9001 / EN 29001, is in compliance with the directive 89/336/CEE on the electromagnetic compatibility and the CE mark confirms the compliance of the product. The device is housed in a rough self extinguish plastic container suitable for mounting on DIN rails. A version of this device for mounting on DIN B head is also available.

Input types

The DAT 2015 is configurable for any of the following input types:

- **RTD** input for linearised PT100, PT1000, Ni100 and Ni1000. The cable compensation is possible by 3 or 4 wire connection.
- **Thermocouple** input for 8 different types. The Cold Junction Compensation is selectable as internal or external.
- **Current** input from -10 to +24 mA.
- **Voltage** input up to -400/+700 mV or up to +/-10 V
- **Resistance** input for linear resistance measurement from 20 Ohm to 2 KOhm with 3 or 4 wire compensation.
- **Potentiometer** input from 20 Ohm to 50 KOhm.

Output

Programmable or standard 4 - 20 mA current output. Programmable Sensor Burnout as "Upscale" or "Downscale". Protection against polarity reversal is provided.

Set-Up

All the configurable functions and parameters are easily programmed by means of a PC with a software package, named PROSOFT, developed by DATEXEL. This "guide lines menu" type program operates under "Windows95TM" on a PC which communicates, via an interface adapter, with the DAT 2015. The adapter is connected through a cable to an apposite connector situated on the transmitter (for more detailed information, see the figure in the next page).

IMPORTANT: On request the transmitter can be supplied configured for the desired sensor type and calibrated for the specific range as defined in the order (see "HOW TO ORDER").

DAT 2015 BLOCK AND WIRING DIAGRAM

E&OE

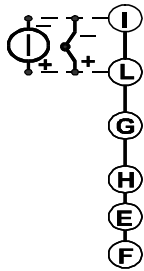
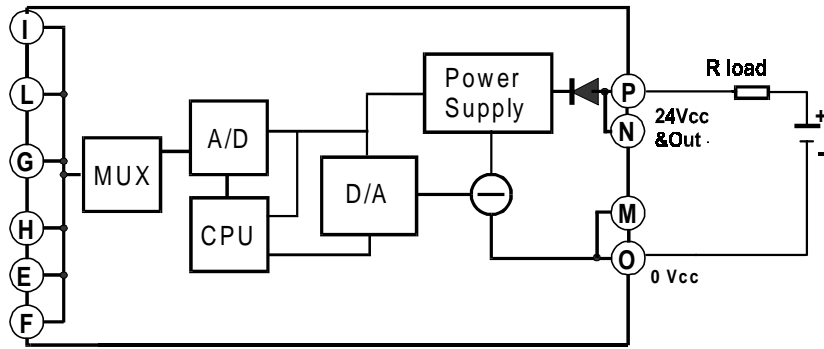

mV / TC

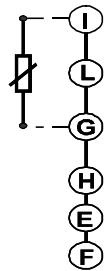

RTD/RES 2 WIRE

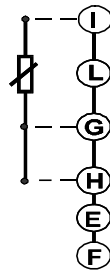

RTD/RES 3 WIRE

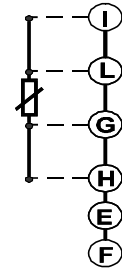

RTD/RES 4 WIRE

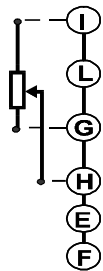

POTENTIOMETER

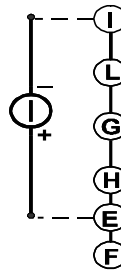

Volt

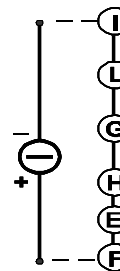

mA

CONFIGURATION

This operation is carried out, using a Personal Computer with "Windows95™" operating system, by the software PROSOFT, specifically developed by DATEXEL, and by the interfacing adapter PRODAT-03. The software includes a window-type program by which the operator is guided through the operations to be executed. Once the data are inputted, a few seconds is the time necessary to complete a configuration cycle.

The parameters which is possible to configure are illustrated in the "Configuration options" in the page here at side. Furthermore it is possible, in the same phase, to program the "zero" and the "full scale" values. The calibration of the device is made automatically, with the maximum accuracy, without the need of any mechanical regulation. The configuration is normally made at the factory in conformity to the customer's order or, alternatively, in one of the most used configuration: DAT2015 / Pt100-0..200°C / S.L. / 3-wire / 4..20mA / Upscale.

The device can be reconfigured for any number of times. This operation is possible also when the device is operating in the plant or in the field because it is possible, by software, to interrupt momentarily the normal operation which restarts automatically after the configuration. In the case that the power supply unit is not available, the transmitter can be configured using a 9 V battery.

The complete configuration system (which includes: interface module PRODAT-03 and software) is supplied from DATEXEL at economical price.



DAT 2015

PRODAT-03

DAT 2015

DAT 2015 Technical Specifications

(typical @ 25°C and in the nominal conditions)

Input

RTD			
Input	Min	Max	Span Min
PT100	-200°C	850°C	50°C
PT1000	-200°C	200°C	50°C
NI100	-60°C	180°C	50°C
NI1000	-60°C	150°C	50°C

TC			
Input	Min	Max	Span Min
J	-200°C	1200°C	2 mV
K	-200°C	1370°C	2 mV
S	-50°C	1760°C	2 mV
R	-50°C	1760°C	2 mV
B	400°C	1820°C	2 mV
E	-200°C	1000°C	2 mV
T	-200°C	400°C	2 mV
N	-200°C	1300°C	2 mV

Voltage			
Input	Min	Max	Span Min
mV	-100	+700	2 mV
mV	-400	+400	2 mV
V	-10V	+10V	500 mV

Potentiometer			
Range	Min	Max	Span Min
Ohm	20	200	10%
Ohm	200	500	10%
KOhm	0.50	50	10%

Resistance			
Input	Min	Max	Span Min
Low	20 Ohm	300 Ohm	10 Ohm
High	300 Ohm	2000 Ohm	200 Ohm

Current			
Input	Min	Max	Span Min
mA	-10mA	+24 mA	2 mA

Input impedance

TC, mV >=10 MOhm
V >= 1 MOhm
Current ~50 Ohm

Lead wire resistance influence

TC, mV, V >=0.8uV/Ohm
RTD 3-wire 0.05%/Ohm (50 Ohm max) (2)
RTD 4-wire 0.005%/Ohm (100 Ohm max)

RTD Sensor Current

Typical 0.350 mA

E&OE

Output

Current Output

Signal range (4 - 20 mA) or (20 - 4 mA)
Load Resistance (see Load Characteristic)

Accuracy

Linearity TC ±0.2 % (1)
RTD ±0.1 % (1)

Calibration

RTD The larger of ±0.1%(1) and ±0.2 °C
Res. Low The larger of ±0.1%(1) and ±0.15 Ohm
Res. High The larger of ±0.2%(1) and ±1 Ohm
mV, TC The larger of ±0.1%(1) and ±18 uV
V The larger of ±0.1%(1) and ±2 mV
Input current The larger of ±0.1%(1) and ±6 uV
Cold junction comp. ±0.5 °C
Output current ±7 uA

Thermal Drift

Full Scale ±0.01%/°C
Cold junction Compensation ±0.01%/°C

Common data

Supply

Supply Voltage 10 - 32 Vdc
Polarity protected 60 Vdc

Temperature & Humidity

Ambient Temperature -20 °C to +70 °C
Humidity (not condensig) 0 to 90%

EMC

Emission EN50081-2
Immunity EN50082-2
RF Immunity tested for 10V/m up to 1000MHz

Response time

Rise time(10 - 90 %) 0.4 sec. approx.

Housing

Material Selfextinguish plastic
Mounting DIN B head or bigger
Weight Approx. 50 g

Note:(1) of input span
(2) Balancing required

RI06045