



RAYLEIGH INSTRUMENTS LIMITED

Raytel House · Brook Road · Rayleigh · Essex SS6 7XH
Tel: (01268) 749300 · Fax: (01268) 749309
Internet: <http://www.rayleigh.co.uk>
e-mail: sales@rayleigh.co.uk

Isolated interface for normalized signals

E&OE

DAT 402 - 3W

FEATURES

- 2000Vac galvanic isolation between input and output
- Self-powered input circuit (4÷20 mA)
- Voltage or current output
- High precision
- Maximum stability of characteristics
- Conform to EMC standards - CE mark
- Suitable for mounting on DIN rail
- Very thin case

APPLICATIONS

- Isolation of normalized signal in:
- Process controls
 - Automation systems



GENERAL INFORMATION

The DAT 402 3W is an isolated interface suitable for the conversion of a 4-20 mA current loop signal in a normalized signal while maintaining a galvanic isolation between input and output sides. The input circuit is connected in series to the current loop and is self-powered by the input signal, subtracting to the loop a maximum voltage of 6 V at 20 mA. The output signal can be a current (0-20 mA 4-20 mA) or a voltage (0-10 V).

The device, conform to the 89/336/EEC directives on electromagnetic compatibility, is contained in a rugged plastic case suitable for direct mounting on DIN rail complying with DIN 46277-1 and DIN 46277-3 standards.

TECHNICAL SPECIFICATIONS (Typical @ 25°C and in the nominal conditions)

Input

Input signal	4÷20 mA
Maximum input current	40 mA
Maximum voltage drop in the loop	6 V @ I _{in} =20 mA
Protection against polarity reversal	60 V reverse max.

Output

	0÷10 V	0÷20 mA	4÷20 mA
Load resistance	2 K Ω min.	500 Ω max.	500 Ω max.
Protection against polarity reversal	60 V reverse max.	60 V reverse max.	60 V reverse max.
Response time (10 to 90% of full scale)	0.08 seconds	0.08seconds	0.08 seconds
Warm-up time	3 minutes	3 minutes	3 minutes
Current consumption @ 24 Vdc	10 mA max.	30 mA max.	30 mA max.

Performances

Calibration error	± 0.1% of full scale
Linearity error (inclusive of hysteresis and variations of supply voltage)	± 0.15 % of full scale
Electromagnetic Compatibility	According to EN50081-2 and EN50082-1
Thermal drift	0.02% of full scale/°C
Supply voltage on output side	18 ÷ 30 V
Isolation voltage between input side and output side	2000 Vac, 50 Hz, 1 min.
Operating temperature	- 20 ÷ 70 °C
Storage temperature	- 40 ÷ 100 °C
Relative humidity (non-condensing)	0 ÷ 90 %
Weight	50 grams

WORKING DIAGRAM

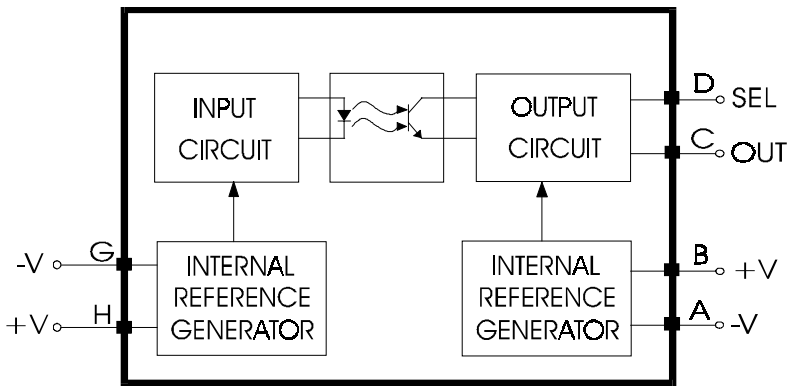

APPLICATION DIAGRAM

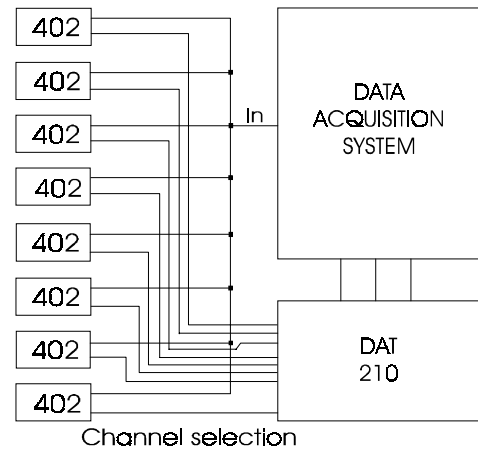

E&OE

OPERATING INSTRUCTIONS

Input side: The conditioner must be connected in series to the current loop between the terminals G(+V) and H(-V). The input is self-powered and don't require any other connections to power it.

The maximum voltage drop is 6 V at 20 mA. The device is internally protected against supply voltage polarity reversal.

Output side: The conditioner must be powered on the output side with a voltage in the 18 ÷ 30 V range applied between terminals B (+V) and A (GND). The output signal, which can be either in voltage or in current, is referenced to terminal A and is supplied on terminal C. Applying to the terminal D a voltage in the range 5 ÷ 30 V, the output circuit enter in high impedance state and become possible to connect several modules to the same A/D converter input. Also the output side is internally protected against input voltage polarity reversal. The maximum voltage that can be applied between input and output must not surpass 2000 Vac in any case.

To further protect the device against electrostatic discharges which could be originated by its handling before the installation, it is supplied with an apposite transparent plastic cover which can be removed during the installation.

PHYSICAL DIMENSION

(all measures in mm.)

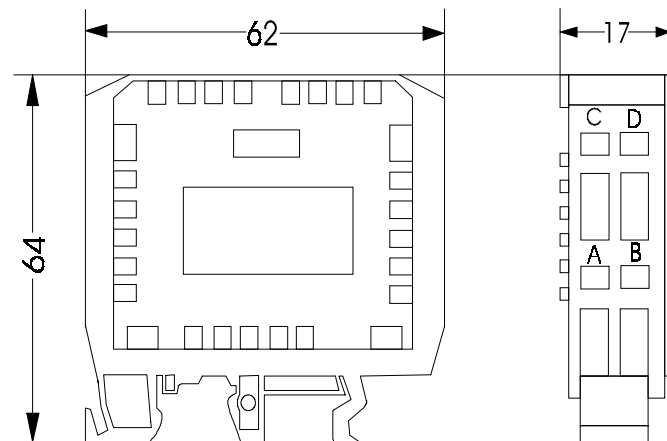

WIRING DIAGRAM

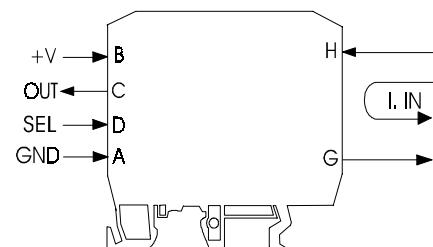

PIN ARRANGEMENT

A = GND OUT	E = NC
B = + V OUT	F = NC
C = OUT	G = - IN
D = SEL	H = + IN

HOW TO ORDER:

DAT 402 3W - 0/10

Output chosen
(0 ÷ 10V, 0 ÷ 20 mA,
4 ÷ 20 mA)

RI06071