



RAYLEIGH INSTRUMENTS LIMITED

Raytel House · Brook Road · Rayleigh · Essex SS6 7XH
Tel: (01268) 749300 · Fax: (01268) 749309
Internet: <http://www.rayleigh.co.uk>
e-mail: sales@rayleigh.co.uk

Programmable transmitter for thermocouple

E&OE

DAT 1120

FEATURES

TC input from E, J, K, N, S, R, B e T type
Two wire 4-20 mA voltage linear output
Zero and span programmable by DIP SWITCH
Good accuracy and performance stability
Programmable for both °C & °F scales
One model cover both K & J TC type.
Conform to EMC standards - CE mark
Suitable for mounting on DIN B connection heads
Low cost

APPLICATIONS

Temperature monitoring and controlling in:

- Process controls
- Automation systems
- Energy sources management



GENERAL INFORMATION

The two wire DAT1120 transmitter has been designed to give an output current signal of 4-20 mA; this signal is perfectly linear and proportional to the voltage generated by the thermocouple sensor connected to its input. The output current signal is supplied on the same two wires used to power the device.

The user can program the full scale easily and quickly by means of four way DIP switch. The "zero" value can be varied between -50°C to +50°C or -100 to +100 °F and the span value can be programmed following TC limits only. The maximum accuracy and reliability are ensured for all the functions (conditioning, cold junction compensation and current transmission) thanks to the employment of high precision and high-quality components and to the use of the SMD technology. The device, conform to the 89/336/EEC directives on electromagnetic compatibility, is housed in a rugged self-extinguishing plastic case suitable for direct mounting on the connection head.

TECHNICAL SPECIFICATIONS (Typical @ 25°C and in the nominal conditions)

Input

Type of sensor TC type K, J, S, N, E, T, B and R according to SIPT68
Zero Programmable in the -50°C to +50°C range or -100°F to 100°F
Span Programmable according to version table.
Influence of line resistance 0,2 $\mu\text{V} / \Omega$

Output

Sensor interruption signaling Positive out of scale (< 3.5 mA on request)
Measuring current 4-20 mA, two wires
Current limitation about 35 mA
Protection against polarity reversal 60 V reverse max
Response time (10 to 90% of full scale) 0.3 s.
Warm-up time 3 minutes

Performances

Calibration inaccuracy $\pm 0.1\%$ of f.s. or $\pm 0.2^\circ\text{C}$
Linearity error (inclusive of hysteresis and supply voltage variations) $\pm 0.1\%$ of full scale
Electromagnetic Compatibility (EMC) According to EN50081-2 and EN50082-2
Thermal drift 0.03% of full scale/°C
Power supply voltage 12 - 32 V
Operating temperature - 20 - 70 °C
Storage temperature - 40 - 100 °C
Relative humidity (non-condensing) 0 - 90 %
Weight 35 grams

WORKING DIAGRAM

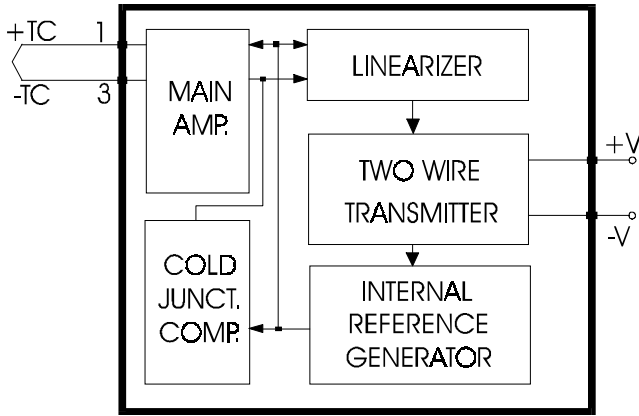

LOAD CHARACTERISTICS

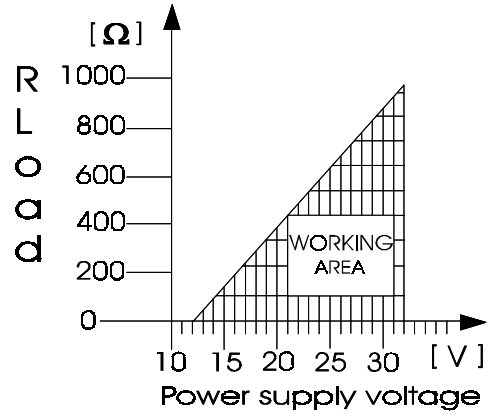

OPERATING INSTRUCTIONS

The transmitter must be powered with a voltage ranging from 12 to 32 V, applied between the -V and +V terminals. The permissible Rload resistance, equivalent to that of the instruments applied in series to the voltage generator, must be determined as a function of the power supply voltage value and according to the load characteristic so that its value is covered by the working area. DAT 1120 is available in 6 different versions, covering all common sensors types. For most common sensors a single unit cover 2 sensors, allowing substantial reduction of stocks. The scale range can be programmed in a quick and easy way: the span value must be setted giving the DIP switch a configuration according to the dedicated "Programming sheet", then, after simulating at the input the zero scale, adjust the "zero" potentiometer so as to obtain a 4 mA indication, finally, simulating the full scale, adjust the "span" potentiometer to get a 20 mA indication. Repeat these adjustments until the requested accuracy is achieved.

WIRING DIAGRAM

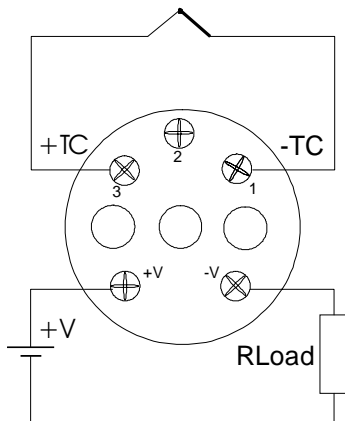

VERSION TABLE

| Version | Sensor | Programmable Span |
|---------|--------|--|
| 1 | K & J | 100 - 1400°C / 200 - 2500°F (K) 100 - 950°C / 200 - 1800°F (J) |
| 2 | R & S | 650 - 1760°C / 1200 - 3200°F (R) 700 - 1760°C / 1290 - 3200°F (S) |
| 3 | T | 100 - 350°C / 200 - 600°F |
| 4 | B | 900 - 1820°C / 1600 - 3250°F |
| 5 | N | 150 - 1350°C / 250 - 2400°F |
| 6 | E | 50 - 1050°C / 100 - 1900°F |

PHYSICAL SIZE
(measures in mm.)

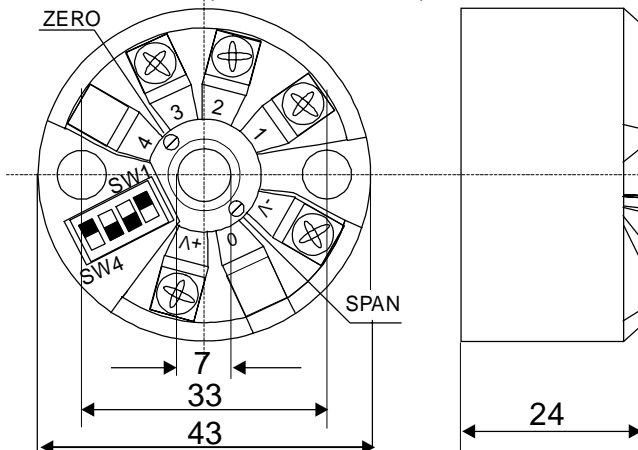

HOW TO ORDER:

DAT 1120 - 1
Version _____

RI06125