

SINGLE BEAM

Series SAB 116

This barrier is designed to prevent inadvertent access to a dangerous area. By mounting the beam at 750mm from the ground, the risk of stepping over the beam is minimised and this degree of protection has been found to be adequate for slow speed machinery.

The Series SAB 116 can also be used as an alternative to the Series 600, 700, 800, 900 and 1000.

By using two mirrors, up to three sides of a machine can be protected with only one transmitter/receiver.

Standard and long range versions are available.

The unit features LEDs which operate as described below.

Yellow	Red	Green	Result
OFF	ON	OFF	No power
OFF	ON	OFF	No alignment or test circuit off
Flashing	ON	OFF	Near alignment
OFF	OFF	ON	Alignment
ON	ON	OFF	Test circuit on



Single Beam SAB 116

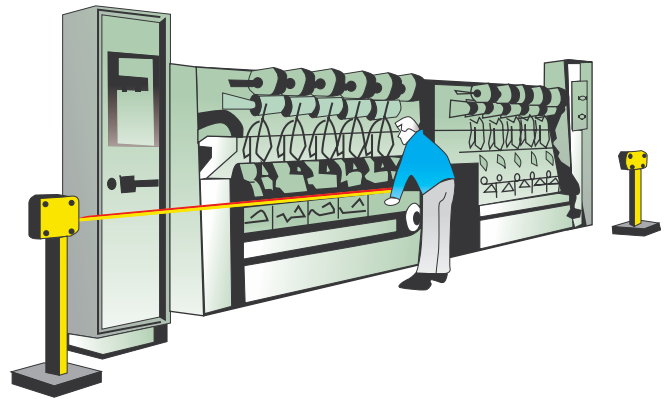

Single Beam (Series SAB 116) Horizontal

CODE REFERENCE FOR ORDERING

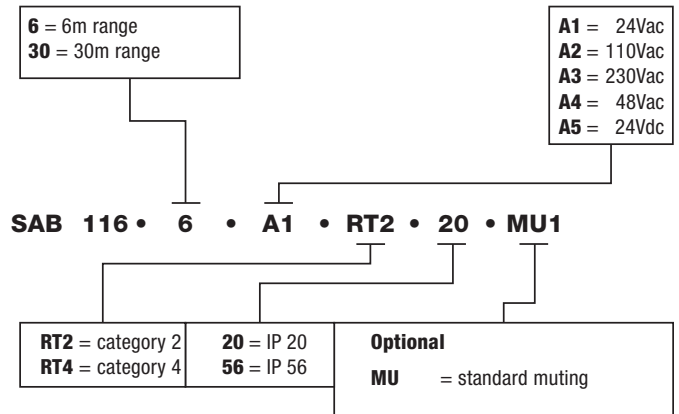

Series SAB 200 / SAB 400

MULTIPLE BEAM LIGHT BARRIERS

Series SAB 200 High Resolution

This barrier has a resolution of 30mm and offers protection for hands and arms.

It is used to guard the access to presses, cutting and rolling machines etc., which require the protective barrier to be close to the pinch point. The design of the electronic circuit ensures that the emitter and receiver are not affected by ambient or artificial light, flashes, stroboscopic lamps etc..

Series SAB 400 Medium Resolution

This barrier provides a more economical solution than the Series 200 since it has a resolution of 50mm. It is used to protect hands, arms and legs and should be installed far enough from the pinch point of the machinery to give adequate protection in accordance with standard EN999.

A typical function would be the protection of legs when used in the horizontal mode.

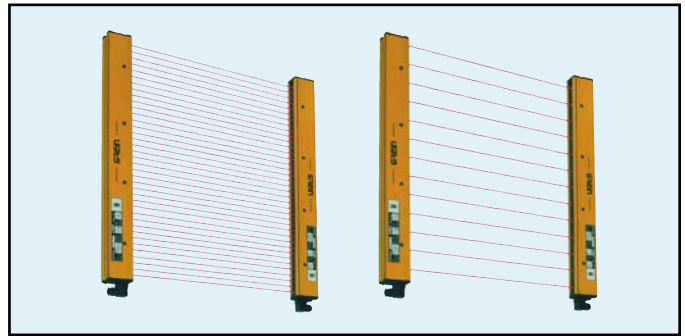

Multi Beam SAB 200, 400

Multiple Beam Light Barriers

(SAB 2/400) Horizontal & Vertical

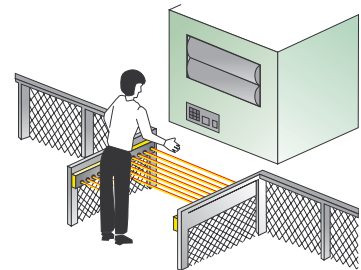
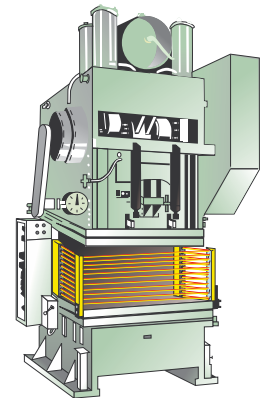

TECHNICAL DATA

Series SAB 200 and 400

TYPE	Nº. OF BEAMS	PROTECTED HEIGHT PH	SENSING HEIGHT PH	BARRIER HEIGHT PH	WEIGHT TX + RX	RESPONSE TIME
Series SAB 200 - Beam spacing 20mm - Resolution Ø 30mm						
2.04	4	110mm	70mm	192mm	1.7Kg	7ms
2.08	8	190mm	150mm	192mm	1.8Kg	7ms
2.12	12	270mm	230mm	272mm	2.0Kg	8ms
2.16	16	350mm	310mm	352mm	2.5Kg	10ms
2.24	24	510mm	470mm	512mm	3.5Kg	11ms
2.32	32	670mm	630mm	672mm	4.5Kg	13ms
2.40	40	830mm	790mm	832mm	5.5Kg	15ms
2.48	48	990mm	950mm	992mm	6.5Kg	16ms
2.56	56	1150mm	1110mm	1152mm	7.5Kg	18ms
2.64	64	1310mm	1270mm	1312mm	8.5Kg	20ms
2.72	72	1470mm	1430mm	1472mm	9.5Kg	21ms
2.80	80	1630mm	1590mm	1632mm	10.5Kg	22ms
2.88	88	1790mm	1750mm	1792mm	11.5Kg	24ms
2.96	96	1950mm	1910mm	1952mm	12.5Kg	26ms
Series SAB 400 - Beam spacing 40mm - Resolution Ø 50mm						
4.04	4	210mm	130mm	192mm	1.8Kg	6ms
4.06	6	290mm	210mm	272mm	2.0Kg	7ms
4.08	8	370mm	290mm	352mm	2.5Kg	7ms
4.12	12	530mm	450mm	512mm	3.5Kg	8ms
4.16	16	690mm	610mm	672mm	4.5Kg	10ms
4.20	20	850mm	770mm	832mm	5.5Kg	11ms
4.24	24	1010mm	930mm	992mm	6.5Kg	11ms
4.28	28	1170mm	1090mm	1152mm	7.5Kg	12ms
4.32	32	1330mm	1250mm	1312mm	8.5Kg	13ms
4.36	36	1490mm	1410mm	1472mm	9.5Kg	14ms
4.40	40	1650mm	1570mm	1632mm	10.5Kg	15ms
4.44	44	1810mm	1730mm	1792mm	11.5Kg	15ms
4.48	48	1970mm	1890mm	1952mm	12.5Kg	16ms

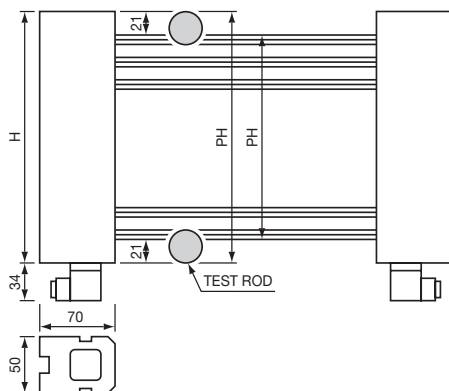

CODE REFERENCE FOR ORDERING

2 = beam spacing 20mm 4 = beam spacing 40mm	Number of Beams (See Table)	SD = without bar graph CD = with bar graph	A1 = 24Vac A2 = 110Vac A3 = 230Vac A4 = 48Vac A5 = 24Vdc
------------------------------------------------	--------------------------------	-----------------------------------------------	----------------------------------------------------------------------

SAB 2 • 24 • SD • A2 • 4 • 20 • MS-E

2 = category 2 4 = category 4	20 = IP 20 56 = IP 56	Optional
----------------------------------	--------------------------	-----------------

Example:-
SAB-224•SD•A2•4•20•MS-E
= Safety Barrier beam spacing 20mm, 24 beams, without bar graph, power supply 110Vac, category 4, control box IP 20, with entry sequential muting

Optional
MU 0.5 = standard muting 0.5sec
MU1 = standard muting 1sec
MS-E = entry sequential muting
MS-O = exit sequential muting
L = range 5 - 30 meters
 Only for angled barriers:
V = Vertical
O = Horizontal

TECHNICAL DATA

Series SAB	116	200	400	600	700	800	900	1000	200**	400-600**
Range	6÷30m	15÷30m	15÷30m	15÷30m	15÷30m	15÷30m	15÷30m	15÷30m	15÷30m	15÷30m
Sensing Height	-	70÷1910mm	130÷1890mm	230÷1670mm	310÷1750mm	390÷1670mm	470÷1670mm	550÷1510mm	70÷1910mm	130÷1670mm
Beam Spacing	-	20mm	40mm	160mm	240mm	320mm	400mm	480mm	20mm	40÷160mm
Resolution	4÷10m	30mm	50mm	110mm	190mm	279mm	350mm	430mm	30mm	50÷110mm
N°. of Beams/arrays	1	4÷96	4÷48	2÷11	2÷8	2÷6	2÷5	2÷4	4÷96	4÷48

**Angled Barriers

SPECIFICATIONS

Optical

Lenses diam. 15mm
(with 10 x 15mm diaphragm)
Resolution 30 to 430mm (depending on type)
Conical angle or emitter/receiver < 4°
Beam spacing 20 to 480mm (depending on type)
Optical interface 20,000 LUX for solar and optical light penetration
Total immunity to welding sparks, flashes, stroboscopic lights
Light source GaAs light emitting diode, 950nm

Control Box

Power supply 24-48-110-220V ac +10-20%
50/60Hz or 24V dc to be specified
Contacts 2 N/O, 1N/C
Output safety relays 6A 250V ac
Mechanical operations over 2.500.000
Response time 7-20ms
(depending on number of beams)
on restart 100ms
Consumption lower than 10W
Enclosure fibre-glass reinforced plastic IP 20
(on request IP 56)
Connections DIN-rail enclosure 32 terminal connector block

Emitter/Receiver Columns

Material Aluminium alloy
Size 50 x 70mm section, with variable height depending on the number of beams
Operating range 15m (standard),
5 - 30m (long range)
Emitter display 8 LEDs indicating the alignment
Noise immunity in accordance with IEC.801-4 category 4
Temperature range -5°C to +65°C
Relative humidity 95% max. non-condensing
Degree of enclosure IP 65
Colour Yellow RAL 1.021
Reference standard pr.EN 61.496/1-2, category 2 & 4
pr.EN 50100/1-2, category 2 & 4
Vibration immunity 5-60Hz at 5G peak vibration level in three directions

DEFINITIONS

ESPE/AOPD

Electro Sensitive Protective Equipment and Active Opto-electronic Protective Device. The latter consists of one or more emitting and receiving elements and produces an optical field with a specified detection capability.

Detection Zone

Area in which a test piece will be detected by the ESPE.

Resolution

Smallest object that can be detected in the protected zone.

Test Piece

Test rod used to check the detection zone.

Muting

Temporary automatic suspension of the safety function by means of a safety control system during the normal operation of a machine.

OSSD

Out-put switching device. These are the ESPE components that respond by going to the OFF state, when the sensing function is active.

Safety Distance

Value (S) in mm between the optical field of an ESPE and the nearest pinch point.

Total Response Time

Maximum time between activation of the sensory function and the OSSD going to the OFF state. Made up of T1 + T2, where:-

- T1 = response time of machinery in milliseconds.
- T2 = response time of control box plus that of barrier (emitter/receiver) in milliseconds.

SPECIFIC DEFINITIONS

PH = Protected Height, in mm: zone in which the test rod will stop the machinery.

SH = Sensitive Height, in mm: zone covered by infra-red beams.

B = Beam spacing centres, in mm.

A = Active part of lens, in mm.

d = System Resolution
(ie. detection capacity), in mm: smallest object that can be detected in the protected zone.

At least 2 adjacent beams must be obscured with a test rod of a diameter equal to the barrier's resolution (Series 200/400).

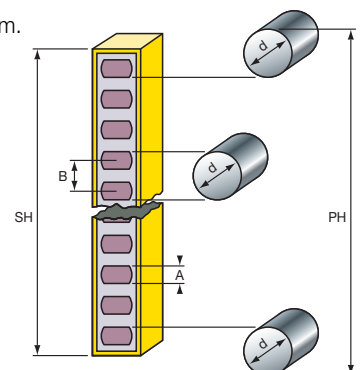

Series SAB 600/700/800/900/1000

PERIMETER AND AREA GUARDING

Series SAB 600 and 700 With double beam light arrays

This series provides perimeter or area protection to prevent access during hazardous machine operations. The applications can be similar to those for which the Series 400 is used. The resolution however is lower than the Series 400, thus providing a more economical solution for the same barrier height. These barriers are available in both standard and long range versions.

Series SAB 800, 900 and 1000

This series of pedestrian barriers is suitable for robot applications, palletizers, automated assembly plants etc.. They are normally mounted vertically. The safety distance between the barrier and the critical danger or pinch point must be calculated in accordance with the standard EN999. These barriers are available in both standard and long range versions.

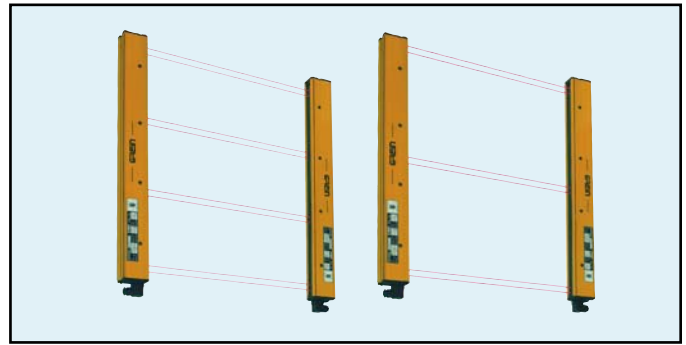

Perimeter/Area Guarding
SAB 6/7/8/900 & 1000

Perimeter/Area Guarding

(Series SAB 6/700)
Horizontal and Vertical

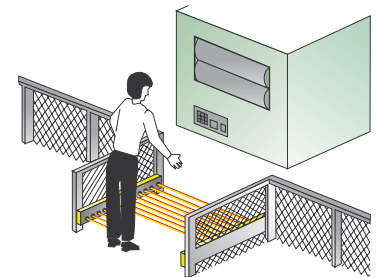

Perimeter/Area Guarding

(SAB 8/900 & 1000)
Usually Vertical

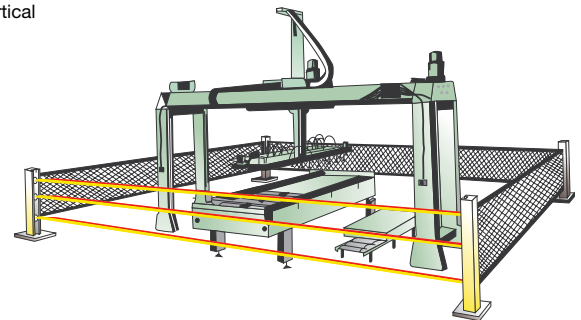

TECHNICAL DATA

Series SAB 600, 700, 800, 900 and 1000

TYPE	N° OF ARRAYS	SENSING HEIGHT PH	BARRIER HEIGHT PH	WEIGHT TX + RX	RESPONSE TIME
Series SAB 600 - Beam spacing 160mm - Resolution Ø 110mm					
6.02	2	230mm	272mm	1.5Kg	6ms
6.03	3	390mm	512mm	3.5Kg	7ms
6.04	4	550mm	672mm	4.57Kg	7ms
6.05	5	710mm	832mm	5.5Kg	8ms
6.06	6	870mm	992mm	6.5Kg	8ms
6.07	7	1030mm	1152mm	7.5Kg	9ms
6.08	8	1190mm	1312mm	8.5Kg	10ms
6.09	9	1350mm	1472mm	9.5Kg	10ms
6.10	10	1510mm	1632mm	10.5Kg	10ms
6.11	11	1670mm	1792mm	11.5Kg	11ms
Series SAB 700 - Beam spacing 240mm - Resolution Ø 190mm					
7.02	2	310mm	352mm	2Kg	6ms
7.03	3	550mm	672mm	4Kg	7ms
7.04	4	790mm	832mm	5Kg	7ms
7.05	5	1030mm	1152mm	7Kg	8ms
7.06	6	1270mm	1312mm	8Kg	8ms
7.07	7	1510mm	1552mm	9Kg	9ms
7.08	8	1750mm	1792mm	10Kg	10ms
Series SAB 800 - Beam spacing 320mm - Resolution Ø 270mm					
8.02	2	390mm	512mm	3Kg	6ms
8.03	3	710mm	832mm	4Kg	7ms
8.04	4	1030mm	1152mm	8Kg	7ms
8.05	5	1350mm	1472mm	9Kg	8ms
8.06	7	1670mm	1792mm	10Kg	8ms
Series SAB 900 - Beam spacing 400mm - Resolution Ø 350mm					
9.02	2	470mm	512mm	4Kg	6ms
9.03	3	870mm	992mm	7Kg	7ms
9.04	4	1270mm	1312mm	9Kg	7ms
9.05	5	1670mm	1792mm	10Kg	8ms
Series SAB 1000 - Beam spacing 480mm - Resolution Ø 430mm					
10.02	2	550mm	672mm	4Kg	6ms
10.03	3	1030mm	1152mm	7Kg	7ms
10.04	4	1510mm	1552mm	9Kg	7ms

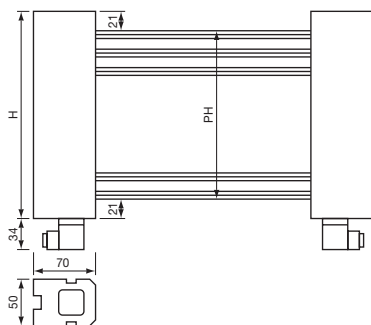

CODE REFERENCE FOR ORDERING

6 = array spacing 110mm	Number of Arrays (See Table)	SD = without bar graph	A1 = 24Vac
7 = array spacing 190mm		CD = with bar graph	A2 = 110Vac
8 = array spacing 270mm			A3 = 230Vac
9 = array spacing 350mm			A4 = 48Vac
10 = array spacing 430mm			A5 = 24Vdc

SAB 9 • 03 • CD • A5 • 4 • 56 • MU1

2 = category 2	20 = IP 20	Optional
4 = category 4	56 = IP 56	
<p>Example:- SAB-903•CD•A5•4•56•MU1 = Safety Barrier 3 array beam spacing 350mm, with bar graph, power supply 24Vdc, category 4, control box IP 56, with muting 1sec</p>		
<p>MU 0.5 = standard muting 0.5sec MU1 = standard muting 1sec MS-E = entry sequential muting MS-O = exit sequential muting L = range 5 - 30 meters Only for angled barriers: V = Vertical O = Horizontal</p>		

CONTROL UNIT RT

The RT control unit operates as described previously to monitor signals from the barrier and control the supply to the machine. It is supplied in an ABS reinforced box for IP20 protection, although IP56 is available on request. The unit has plug-in terminal blocks for ease of installation and maintenance.

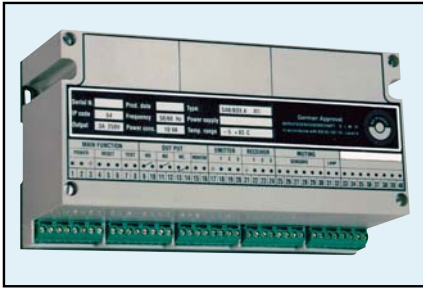

TYPICAL SCHEMATIC

Light barrier with muting function and start/re-start interlock.

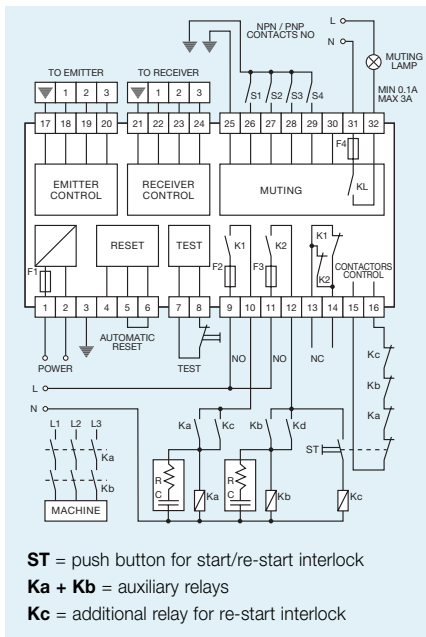

DIMENSIONS

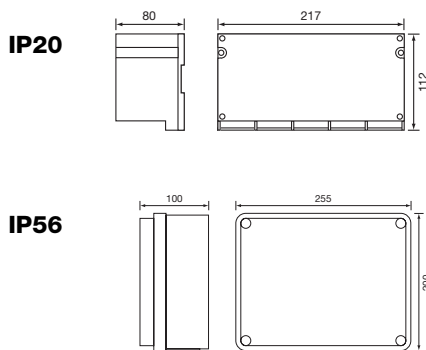

MIRROR APPLICATIONS

The use of mirrors provides an economical means of protecting 2 (L shape) or 3 (U shape) sides of an area using a single barrier. Total protection of 4 sides may be achieved, but it is not generally advisable due to problems with aligning the mirrors. Each mirror will reduce the total barrier range by approximately 15%.

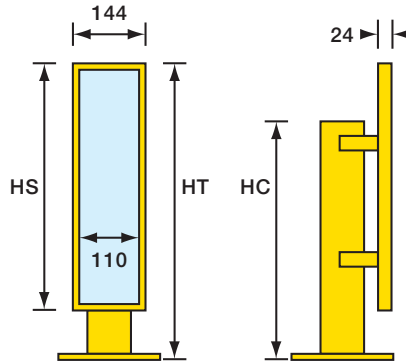

Model	HS	HC	HT min	HT max
WAB 501	390mm	385	400	570
WAB 502	710mm	705	720	1050
WAB 503	1030mm	1025	1040	1530
WAB 504	1350mm	1045	1360	2010
WAB 505	1670mm	1665	1680	2320

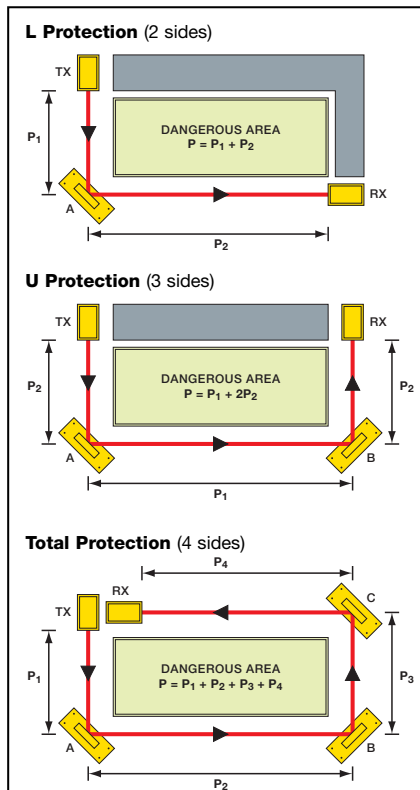

ANGLED BARRIERS

Series SAB 200, 400 and 600

For large presses, handling systems etc., it is important that operators cannot get between the light barrier and the danger area. To prevent this, a horizontal light barrier can be used in conjunction with the vertical light barrier in order to sense operator proximity. One control box is sufficient for two barriers from different series.

The gap between the beams on the vertical and horizontal arrays at the junction of the two barriers must not be greater than that between the beams on the horizontal barrier

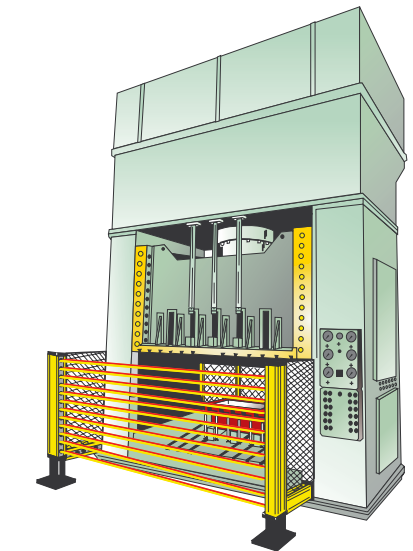

Angled Barrier
 (SAB 200 Vertical, 4/600 Horizontal)